

**Bulldozer Cutting Edges**

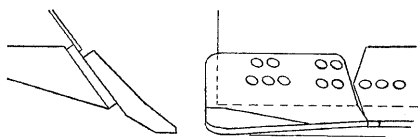

**EWL**  
Extended wear I

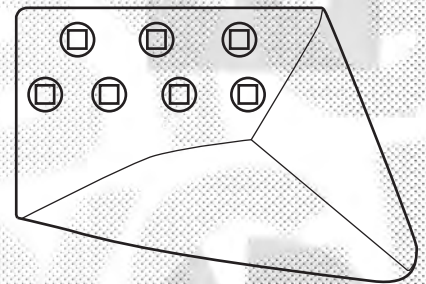
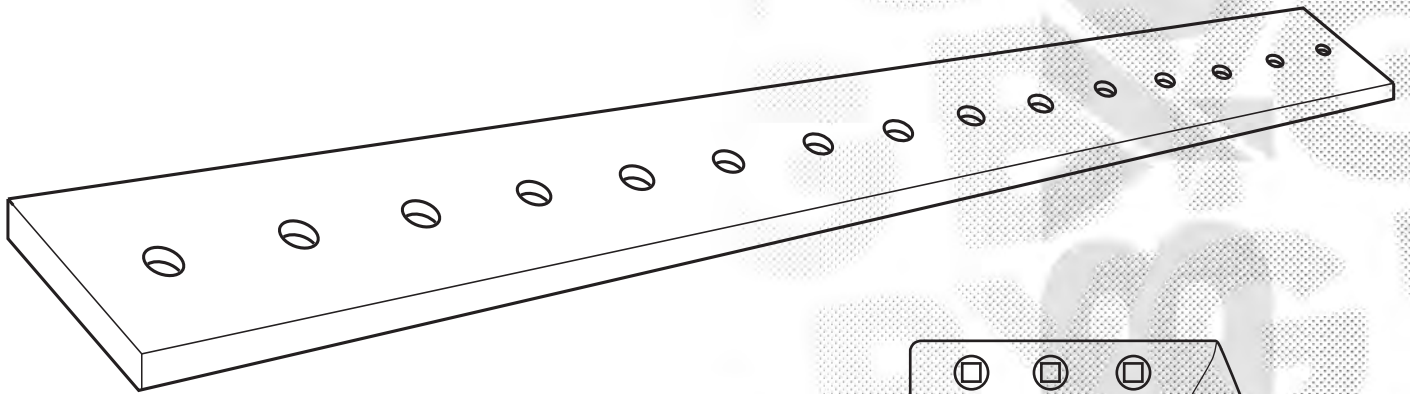
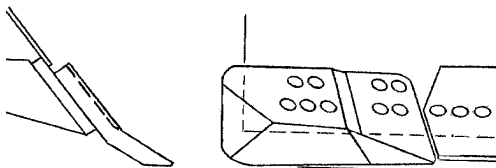

**GD**  
General duty

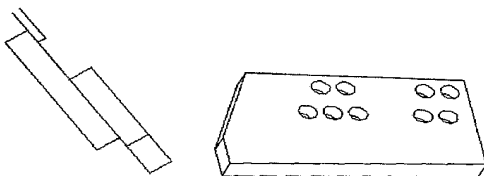

**UTILITY**  
Flat plate design

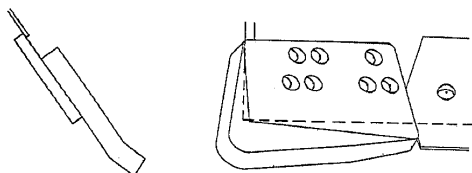

**HOT CUPPED**  
3G, 1U, 7T

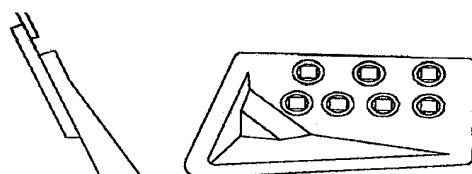

**IMPACT FORGED**  
3J, 4J, 5J, 9J, 9F, 1U, 7T

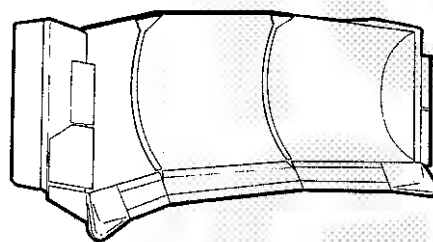

**U-BLADE**  
Is designed with large "wings" to carry large loads over long distances more efficiently.

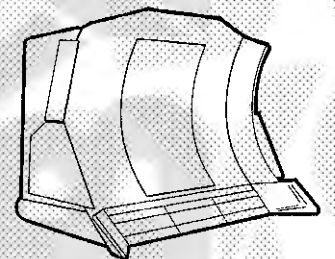



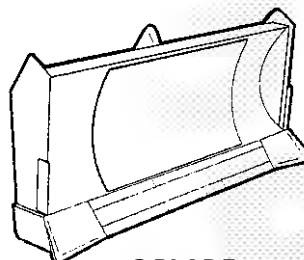



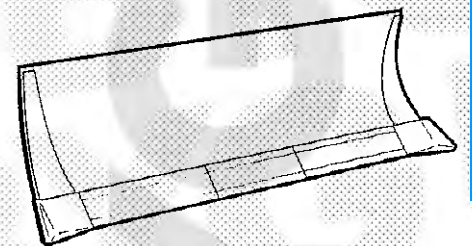













**S-BLADE**  
Is a good general purpose blade for most dozing applications















































**C-BLADE**  
Is a relatively narrow blade designed primarily for pushing scrapers































































**A-BLADE**  
Is an economical, light to medium duty blade designed for use on D8 and smaller machines where the ability to side-cast is desired





























	Type	Serie	Ref.			Inches	n°	mm.					Descriptionn	n°				
			Present	Old														
<b>D3</b>	3A	3P, 85U	<b>4T-6230</b>	8J-7144		5/8x1/4	6	16	152	870			Center Blade	2	16			
<b>D3B</b>	3S		<b>4T-6320 HD</b>	8J-7144 HD			6	16	152	870			Center Blade	2	16			
			<b>4T-6229</b>	8J-6412			3	16	152	330			Lateral Blade	6				
			<b>4T-6229 HD</b>	8J-6412 HD			3	16	152	330			Lateral Blade	6				
	3S	31M, 86U,	<b>4T-6231</b>	8J-7145		5/8x2 1/4	7	16	152	1060				Center Blade	2	20		
			<b>4T-6231 HD</b>	8J-1745 HD			7	20	152	1060				Center Blade	2	25		
			<b>4T-6229</b>	8J-6412			3	16	152	305				Lateral Blade	6			
<b>4T-6229 HD</b>	8J-6412 HD			3	20	152	330				Lateral Blade	8						
<b>D3P LGP</b>		96X	<b>4T-6232</b>	3G-3354		5/8x2 1/4	8	16	152	1216				Center Blade	2	23		
			<b>4T-6232 HD</b>	3G-3354 HD			8	20	152	1216				Center Blade	2	29		
			<b>4T-6229</b>	8J-6412			3	16	152	330				Lateral Blade	6			
			<b>4T-6229 HD</b>	8J-6412 HD			3	20	152	330				Lateral Blade	8			
<b>D4</b>	4S	93C	<b>8A-8580</b>	8A-7907		5/8x2	4	16	203	624				Center Blade	1	16		
			<b>8A-8531</b>	8A-7914		5/8x2	4	16	203	586				Center Blade	3	15		
			<b>9F-7073/4</b>			5/8x2 1/4	6	16						F End Bit	15			
			<b>3G-8321/2</b>	6J-0277/8		5/8x3 1/2	6	22						HC End Bit	17			
	2A, 67F,		<b>4T-2980</b>	5J-6902		5/8x2	16	16	203	1521				Center Blade		38		
			<b>9F-7073/4</b>			5/8x2 1/4	6	16						F End Bit	15			
	<b>3G-8321/2</b>	6J-0277/8		5/8x3 1/2	6	22							HC End Bit	17				
	4A, 40D		<b>4T-2977</b>	5J-6862		5/8x2	18	16	203	1826				Center Blade		46		
			<b>4T-3021</b>	5J-6903		5/8x2	18	20	203	1826				Center Blade		58		
			<b>9F-7073/4</b>			5/8x2 1/4	6	16						F End Bit	15			
			<b>3G-8321/2</b>	6J-0277/8		5/8x3 1/2	6	22						HC End Bit	17			
	<b>D4, D4E</b>	4S	67E, 27F, 94G	<b>5J-6876</b>	2J-7620		5/8x2 1/4	11	16	203	1743				Center Blade		44	
<b>4T-2983</b>				8J-4665			3	16	203	381				Center Blade	1	10		
<b>4T-2972</b>				8J-4666			4	16	203	673				Center Blade	2	17		
<b>4T-3027</b>				8J-1487			3	20	203	383				Center Blade	1	12		
<b>4T-3028</b>				8J-1488			4	20	203	675				Center Blade	2	21		
<b>5J-6885</b>				5J-2993			15	16	203	2353				Center Blade		59		
<b>9F-7073/4</b>						5/8x2 1/4	6	16						F End Bit	15			
<b>3G-8321/2</b>				6J-0277/8		5/8x3 1/2	6	22						HC End Bit	17			
4S, LGP				84E, 19J, 45J	<b>5J-6885</b>	5J-2993		5/8x2	15	16	203	2353				Center Blade		59
					<b>4T-2982</b>	8J-4667		5/8x2	7	16	203	991				Center Blade	1	25
	<b>4T-2972</b>	8J-4666			5/8x2	4	16	203	673				Center Blade	2	17			
	<b>9F-7073/4</b>				5/8x2 1/4	6	16						F End Bit	15				
<b>3G-8321/2</b>	6J-0277/8		5/8x3 1/2	6	22						HC End Bit	17						
<b>D4H</b>	4S	2TC	<b>4T-3720</b>			3/4x2 1/2	6	16	203	859				Center Blade	2	22		
			<b>3G-4285</b>			3/4x2 1/2	4	20	203	425				Lateral Blade		13		
			<b>4T-5407/8</b>			3/4x2 1/2	4	25						EWL End Bit				
4S, LGP	4HC	<b>4T-8940</b>			3/4x2 1/2	8	16	203	1195				Center Blade	2	30			
		<b>3G-4285</b>			3/4x2 1/2	4	20	203	425				Lateral Blade		13			
		<b>4T-5407/8</b>			3/4x2 1/2	4	25						EWL End Bit					
<b>D4</b>	4A	12D, 78D, 5F1-2850	<b>4T-2977</b>	5J-6862		5/8x2	18	16	203	1826				Center Blade		46		
			<b>4T-3021</b>	5J-6903		5/8x2	18	20	203	1826				Center Blade		58		
			<b>4T-3043</b>	5J-6941/2		5/8x2 1/4	3	20						Flat End Bit	15			
		<b>4T-3043/4 HD</b>	5J-6941/2 HD		5/8x2 1/4	3	25						HC End Bit	17				
		97E, 24F,		<b>4T-2979</b>	5J-6874		5/8x2	13	16	203	2029				Center Blade		51	
				<b>4T-3043</b>	5J-6941/2		5/8x2 1/4	3	20						Flat End Bit	15		
<b>4T-3043/4 HD</b>	5J-6941/2 HD				5/8x2 1/4	3	25						HC End Bit	17				



























	Type	Serie	Ref.		Inches		mm.				Description	n°		
			Present	Old		n°								
<b>D4, D4D</b>	4A	52E, 96E, 6F1300-UP,	<b>5J-6873</b>	2J-469	5/8x2	8	16	203	2537		Center Blade		64	
			<b>4T-2974</b>	8J-1489	5/8x2	5	16	203	808		Center Blade	1	20	
		26F, 95G,	<b>4T-2973</b>	8J-1490	5/8x2	6	16	203	859		Center Blade	2	22	
			<b>4T-3043</b>	5J-6941/2	5/8x2 1/4	3	20				Flat End Bit		15	
			<b>4T-3043/4 HD</b>	5J-6941/2 HD	5/8x2 1/4	3	25				HC End Bit		17	
<b>D4H</b>	4A	6AC	<b>4T-8940</b>		3/4x2 1/2	8	16	203	1195		Center Blade	2	30	
			<b>3G-4285</b>		3/4x2 1/2	4	20	203	425		Lateral Blade		13	
			<b>4T-5407/8</b>		3/4x2 1/2	4	25				EWL End Bit			
	4P	9ZB	<b>3G-9306</b>		3/4x2 1/2	6	16	203	883		Center Blade	2	22	
			<b>3G-4285</b>		3/4x2 1/2	4	20	203	425		Lateral Blade		13	
			<b>4T-5407/8</b>		3/4x2 1/2	4	25				EWL End Bit			
	4P, LGP	5EC	<b>4T-8940</b>		3/4x2 1/2	8	16	203	1195		Center Blade	2	30	
			<b>3G-4285</b>		3/4x2 1/2	4	20	203	425		Lateral Blade		13	
			<b>4T-5407/8</b>		3/4x2 1/2	4	25				EWL End Bit			
<b>D5</b>	5S	90H1-690	<b>5J-6879</b>	3J-7640	5/8x2 1/4	11	20	203	1743		Center Blade		55	
			<b>4T-2983</b>	8J-4665	5/8x2 1/4	3	16	203	381		Center Blade	1	10	
			<b>4T-2972</b>	8J-4666	5/8x2 1/4	4	16	203	673		Center Blade	2	17	
			<b>4T-3027</b>	8J-1487	5/8x2 1/4	3	20	203	383		Center Blade	1	12	
			<b>4T-3028</b>	8J-1488	5/8x2 1/4	4	20	203	675		Center Blade	2	21	
			<b>4T-3051/2</b>	5J-6923	5/8x2 1/4	6	20	203	337			Flat End Bit		11
			<b>9F-7073/4</b>		5/8x2 1/4	6	16				F End Bit		15	
			<b>3G-8321/2</b>	6J-0277/8	5/8x3 1/2	6	22				HC End Bit		17	
			90H691-UP 92H, 97H, 10J, 12J	<b>6J-2171</b>	7J-9493	5/8x2 1/4	15	20	203	2229		Center Blade		71
	<b>4T-3025</b>	7J-9474		5/8x2 1/4	7	20	203	1114		Center Blade	1	35		
	<b>4T-3026</b>	6J-0277/8		5/8x2 1/4	4	20	203	556		Center Blade	2	18		
	<b>9F-7073/4</b>			5/8x2 1/4	6	16				F End Bit		15		
	<b>3G-8321/2</b>			5/8x3 1/2	6	22				HC End Bit		17		
	<b>D5H</b>	5S	2BH	<b>3G-6062</b>		3/4x2 1/2	7	20	203	1162		Center Blade	2	37
<b>3G-4285</b>					3/4x2 1/2	4	20	203	425		Lateral Blade		13	
<b>3G-4285 HD</b>					3/4x2 1/2	4	25	203	425		Lateral Blade		17	
<b>4T-5407/8</b>					3/4x2 1/2	4	25				EWL End Bit			
5S PET		4AH	<b>4T-731</b>		3/4x2 1/2	5	20	203	833		Center Blade	2	26	
			<b>3G-4285</b>		3/4x2 1/2	4	20	203	425		Lateral Blade		13	
			<b>3G-4285 HD</b>		3/4x2 1/2	4	25	203	425		Lateral Blade		17	
			<b>4T-5407/8</b>		3/4x2 1/2	4	25				EWL End Bit			
5S LGP		1ZH	<b>1U-2211</b>		3/4x2 1/2	9	20	203	1470		Center Blade	2	47	
			<b>3G-4285</b>		3/4x2 1/2	4	20	203	425		Lateral Blade		13	
			<b>3G-4285 HD</b>		3/4x2 1/2	4	25	203	425		Lateral Blade		17	
			<b>4T-5407/8</b>		3/4x2 1/2	4	25				EWL End Bit			
<b>D5</b>	5A	91H, 96H, 42K	<b>4T-2978</b>	5J-6861	5/8x2 1/4	24	16	203	2435		Center Blade		61	
			<b>5J-6901</b>	1J-5	5/8x2 1/4	24	20	203	2435		Center Blade		77	
			<b>4T-3030</b>	6J-2350	5/8x2 1/4	12	20	203	1216		Center Blade	2	39	
			<b>9F-7075/6</b>		5/8x2 1/4	6	25				F End Bit		15	
			<b>3G-8295/6</b>	6J-0893/4	5/8x2 1/4	6	25				HC End Bit		16	
		93H, 98H, 11J, 13J	<b>5J-6905</b>		5/8x2 1/4	29	16	203	2892		Center Blade		73	
			<b>5J-6897</b>	1J-3	5/8x2 1/4	29	20	203	2892		Center Blade		92	
			<b>4T-3008</b>	7J-9475	5/8x2 1/4	11	20	203	1165		Center Blade	1	37	
			<b>4T-3020</b>	7J-9476	5/8x2 1/4	9	20	203	859		Center Blade	2	27	
			<b>9F-7075/6</b>		5/8x2 1/4	6	25				F End Bit		15	
			<b>3G-8295/6</b>	6J-0893/4	5/8x2 1/4	6	25				HC End Bit		16	

	Type	Serie	Ref.			Inches	mm.							Description	n°		
			Present	Old			n°										
		93H3847-UP	<b>4T-3004</b>	9J-6853	3/4x2 1/2	9	20	203	1438				Center Blade	2	46		
			<b>4J-8261/2</b>		3/4x2 1/2	6	25							F End Bit		16	
			<b>3G-8297/8</b>		3/4x2 1/2	6	22							HC End Bit		15	
	5S	16K, 19R	<b>4T-3024</b>	5J-9205	5/8x2 1/4	28	20	203	2816				Center Blade		89		
			<b>5A-8644</b>		5/8x2 1/4	14	20	203	1407				Center Blade	2	45		
			<b>9F-7073/4</b>		5/8x2 1/4	6	16							F End Bit		15	
			<b>3G-8321/2</b>	6J-0277/8	5/8x3 1/2	6	22							HC End Bit		17	
	<b>D5H</b>	5A	3AH	<b>4T-3013</b>	7J-9477	3/4x2 1/2	7	20	203	1010				Center Blade	1	32	
<b>1U-2207</b>					3/4x2 1/2	6	20	203	960				Center Blade	2	30		
<b>3G-4285</b>					3/4x2 1/2	4	20	203	425				Lateral Blade		13		
<b>3G-4285 HD</b>					3/4x2 1/2	4	25	203	425				Lateral Blade		17		
<b>4T-5407/8</b>					3/4x2 1/2	4	25							EWL End Bit			
5P		2AH	<b>3G-4282</b>		3/4x2 1/2	7	20	203	1149				Center Blade	2	36		
			<b>3G-4285</b>		3/4x2 1/2	4	20	203	425				Lateral Blade		13		
			<b>3G-4285 HD</b>		3/4x2 1/2	4	25	203	425				Lateral Blade		17		
			<b>4T-5407/8</b>		3/4x2 1/2	4	25							EWL End Bit			
5P LGP		1YH	<b>4T-2315</b>		3/4x2 1/2	10	20	203	1557				Center Blade	2	49		
			<b>3G-4285</b>		3/4x2 1/2	4	20	203	425				Lateral Blade		13		
			<b>3G-4285 HD</b>		3/4x2 1/2	4	25	203	425				Lateral Blade		17		
	<b>4T-5407/8</b>			3/4x2 1/2	4	25							EWL End Bit				
<b>D6</b>	6S	9A, 1C, 6C, 15C1-5000	<b>5J-6879</b>	3J-7640	5/8x2 1/4	11	20	203	1743				Center Blade		55		
			<b>4T-3027</b>	8J-1487	5/8x2 1/4	3	20	203	383				Center Blade	1	12		
			<b>4T-3028</b>	8J-1488	5/8x2 1/4	4	20	203	675				Center Blade	2	21		
			<b>4T-2977</b>	5J-6862	5/8x2 1/4	18	16	203	1826				Center Blade		46		
			<b>4T-3021</b>	5J-6903	5/8x2 1/4	18	20	203	1826				Center Blade		58		
			<b>9F-7073/4</b>		5/8x2 1/4	6	16							F End Bit		15	
			<b>3G-8321/2</b>	6J-0277/8	5/8x3 1/2	6	22							HC End Bit		17	
			<b>4T-2976</b>	5J-6906	5/8X 2 1/4	22	16	203	2232				Center Blade		56		
			<b>4T-3023</b>	5J-6898	5/8x2 1/4	22	20	203	2232				Center Blade		71		
			<b>9F-7073/4</b>		5/8x2 1/4	6	16							F End Bit		15	
			<b>3G-8321/2</b>	6J-0277/8	5/8x3 1/2	6	22							HC End Bit		17	
			6S LGP	21H, 41 H	<b>4T-3017</b>	8J-7738	3/4x2 1/4	15	20	203	2334				Center Blade		74
	<b>4T-3013</b>	7J-9477			3/4x2 1/4	7	20	203	1010				Center Blade	1	32		
	<b>4T-3010</b>	7J-9478			3/4x2 1/4	4	20	203	657				Center Blade	2	21		
	<b>4T-3017 HD</b>	8J-7738 HD			3/4x2 1/4	15	25	203	2334				Center Blade		94		
	<b>4T-3013 HD</b>	7J-9477 HD			3/4x2 1/4	7	25	203	1010				Center Blade	1	41		
	<b>4T-3010 HD</b>	7J-9478 HD			3/4x2 1/4	4	25	203	657				Center Blade	2	26		
	<b>5J-1419/20</b>	5J-1419			3/4x2 1/4	6	22							F End Bit		15	
	<b>3G-8319/20</b>	6J-0275/6			3/4x2 1/4	6	22							HC End Bit		16	
	<b>9W-9014/15</b>				3/4x2 1/4	6	25							HC End Bit		17	
	6A	15C5001-UP 39D, 82D, 8E, 9E			<b>4T-2978</b>	5J-6861	5/8x2 1/4	24	16	203	2435				Center Blade		61
					<b>5J-6901</b>	1J-5	5/8x2 1/4	24	20	203	2435				Center Blade		77
					<b>4T-3030</b>	6J-2350	5/8x2 1/4	12	20	203	1216				Center Blade	2	39



























	Type	Serie	Ref.		Inches		mm.				Description	n°		
			Present	Old		n°								
			<b>9F-7075/6</b>		5/8x2 1/4	6	20					F End Bit		15
			<b>3G-8295/6</b>	6J-0893/4	5/8x2 1/4	6	25					HC End Bit		17
		16C5001-UP	<b>5J-6905</b>		5/8x2 1/4	29	16	203	2892			Center Blade		
		37D, 81D, 16E, 3F, 4F, 40H	<b>5J-6897</b>	1J-3	5/8x2 1/4	29	20	203	2892			Center Blade		92
			<b>4T-3008</b>	7J-9475	5/8x2 1/4	11	20	203	1165			Center Blade	1	37
			<b>4T-3020</b>	7J-9476	5/8x2 1/4	9	20	203	859			Center Blade	2	27
			<b>9F-7075/6</b>		5/8x2 1/4	6	20					F End Bit		15
			<b>3G-8295/6</b>	6J-0893/4	5/8x2 1/4	6	25					HC End Bit		17
		44E, 47G, 58G, 18H, 54U	<b>5J-6878</b>	3J-5028	3/4x2 1/4	20	20	203	3048			Center Blade		97
			<b>4T-3009</b>	6J-1406	3/4x2 1/4	10	20	203	1521			Center Blade	2	48
			<b>5J-6878 HD</b>	3J-5028 HD	3/4x2 1/4	20	25	203	3048			Center Blade		123
			<b>4T-3009 HD</b>	6J-1406 HD	3/4x2 1/4	10	25	203	1521			Center Blade	2	61
			<b>4J-8261/2</b>		3/4x2 1/4	6	19					F End Bit		15
			<b>3G-8297/8</b>	4J-8261/2	3/4x2 1/4	6	22					HC End Bit		16
			<b>9W-9010/11</b>		3/4x2 1/4	6	25					HC End Bit		17
<b>D7</b>	7S	17C1-5000, 5A, 84C, 2E 34D, 83D, 17E	<b>4T-2954</b>	5J-6856	3/4 X2 3/4	23	20	254	2334			Center Blade		92
			<b>4T-2864</b>	5J-6850	3/4x2 3/4	23	25	254	2334			Center Blade		117
			<b>3J-2465/6</b>	1J-0979/80	3/4x4 1/2	7	28					F End Bit		28
		23F, 31F, 59F, 14H	<b>5J-6889</b>	2J-6012	3/4 X2 2/1	17	20	254	2534			Center Blade		100
			<b>4T-2946</b>	6J-256	3/4x2 2/1	7	20	254	1114			Center Blade	1	44
			<b>4T-2945</b>	6J-257	3/4x2 2/1	5	20	254	708			Center Blade	2	28
			<b>5J-6830</b>	2J-6011	3/4x2 2/1	17	25	254	2534			Center Blade		127
			<b>4T-2990</b>	6J-258	3/4x2 2/1	7	25	254	1114			Center Blade	1	56
			<b>4T-2991</b>	6J-259	3/4x2 2/1	5	25	254	708			Center Blade	2	36
			<b>4J-8843/4</b>		7/8x2 3/4	7	28					F End Bit		28
			<b>3G-8293/4</b>		7/8x2 3/4	7	22					HC End Bit		27
			<b>3G-8315/6</b>	5J-8767/8	7/8x2 3/4	7	25					HC End Bit		30
			<b>9W-6198/9</b>		7/8x2 3/4	7	35					HC End Bit		0
		60K 53J, 49K, 64K	<b>4T-2922</b>	6J-5340	7/8x2 3/4	5	20	254	759			Center Blade	2	30
			<b>4T-2921</b>	7J-2363	7/8x2 3/4	7	20	254	1064			Center Blade	1	42
			<b>4T-2992</b>	7J-2847	7/8x2 3/4	5	25	254	759			Center Blade	2	38
			<b>4T-2993</b>	7J-9481	7/8x2 3/4	7	25	254	1064			Center Blade	1	54
			<b>4J-8843/4</b>		7/8x2 3/4	7	28					F End Bit		28
			<b>3G-8293/4</b>		7/8x2 3/4	7	22					HC End Bit		27
			<b>3G-8315/6</b>	5J-8767/8	7/8x2 3/4	7	25					HC End Bit		30
			<b>9W-6198/9</b>		7/8x2 3/4	7	35					HC End Bit		0
<b>D7H</b>	7S	6KB1-UP	<b>4T-5318</b>		7/8x2 3/4	6	20	254	894			Center Blade	3	35
			<b>7T-6678</b>		7/8x2 3/4	6	25	279	894			Center Blade	3	49
			<b>4J-8843/4</b>		7/8x2 3/4	7	28					F End Bit		28
			<b>3G-8293/4</b>		7/8x2 3/4	7	22					HC End Bit		27
			<b>3G-8315/6</b>	5J-8767/8	7/8x2 3/4	7	25					HC End Bit		30
			<b>9W-6198/9</b>		7/8x2 3/4	7	35					HC End Bit		0
	7S-LGP	6JB1-UP	<b>4T-3901</b>		7/8x2 3/4	7	20	254	1094			Center Blade	3	43
			<b>7T-6589</b>		7/8x2 3/4	7	25	279	1094			Center Blade	3	61
			<b>4J-8843/4</b>		7/8x2 3/4	7	28					F End Bit		28
			<b>3G-8315/6</b>	5J-8767/8	7/8x2 3/4	7	25					HC End Bit		30
<b>D7</b>	7A	6A, 35D, 17C5001-UP 84D, 6E, 18E	<b>5J-6866</b>	1J-10	3/4x2 3/4	30	20	254	3045			Center Blade		121
			<b>5J-6853</b>	1J-14	3/4x2 3/4	30	25	254	3045			Center Blade		153
			<b>4T-2949</b>	6J-2349	3/4x2 3/4	15	20	254	1521			Center Blade	2	60
			<b>4T-2863</b>	6J-2348	3/4x2 3/4	15	25	254	1521			Center Blade	2	77





























	Type	Serie	Ref.		Inches		mm.				Description	n°		
			Present	Old		n°								
			<b>3J-2465/6</b>	1J-0979/80	3/4x4 1/2	7	28				F End Bit		28	
			<b>3G-8313/4</b>		3/4x4 1/2	7	30				HC End Bit		30	
		72F	<b>4T-2948</b>	5J-6888	3/4x2 3/4	7	20	254	1064		Center Blade	3	42	
		13F, 22F,	<b>4T-2989</b>	5J-6849	3/4x2 3/4	7	25	254	1064		Center Blade	3	54	
		30F, 13H	<b>4J-8843/4</b>	5J-8767/8	7/8x2 3/4	7	28				F End Bit		28	
			<b>3G-8293/4</b>		7/8x2 3/4	7	22					HC End Bit		27
			<b>3G-8315/6</b>		7/8x2 3/4	7	25					HC End Bit		30
			<b>9W-6198/9</b>		7/8x2 3/4	7	35					HC End Bit		0
<b>7DH</b>	7A	4EB1-U	<b>4T-3901</b>	5J-8767/8	7/8x2 3/4	7	20	254	1094		Center Blade	3	43	
			<b>7T-6589</b>		7/8x2 3/4	7	25	279	1094		Center Blade	3	61	
			<b>3G-8293/4</b>		7/8x2 3/4	7	22	0	0		HC End Bit		27	
			<b>3G-8315/6</b>		7/8x2 3/4	7	25	0	0		HC End Bit		30	
<b>7D</b>	7G		<b>4T-2954</b>	5J-6856	3/4x2 3/4	23	20	254	2334		Center Blade		92	
			<b>4T-2864</b>	5J-6850	3/4x2 3/4	23	25	254	2334		Center Blade		117	
<b>D7H</b>	7 Semi-U	4DB1-UP	<b>4T-5318</b>	5J-8767/8	7/8x2 3/4	6	20	254	894		Center Blade		35	
			<b>7T-6678</b>		7/8x2 3/4	6	25	279	894		Center Blade		49	
			<b>1U-1192</b>		7/8x2 3/4	6	20	254	913		Lateral Blade		36	
			<b>7T-6936</b>		7/8x2 3/4	6	25	279	913		Lateral Blade		51	
			<b>4J-8843/4</b>		7/8x2 3/4	7	28				F End Bit		28	
			<b>3G-8293/4</b>		7/8x2 3/4	7	22				HC End Bit		27	
			<b>3G-8315/6</b>		7/8x2 3/4	7	25				HC End Bit		30	
			<b>9W-6198/9</b>		7/8x2 3/4	7	35				HC End Bit		0	
<b>D7</b>	7U	42G	<b>4T-2955</b>	5J-6895	3/4x2 1/2	9	20	254	1359		Center Blade		54	
			<b>4T-2890</b>	5J-6896	3/4x2 1/2	9	25	254	1359		Center Blade		68	
			<b>4T-2952</b>	5J-6839	3/4x2 1/2	5	20	254	803		Lateral Blade		32	
			<b>4T-2985</b>	5J-6812	3/4x2 1/2	5	25	254	803		Lateral Blade		40	
			<b>3G-8293/4</b>	5J-8767/8	7/8x2 3/4	7	22				HC End Bit		27	
			<b>3G-8315/6</b>		7/8x2 3/4	7	25				HC End Bit		30	
		61K, 85D, 94R	<b>4T-2917</b>	7J-2362	7/8x2 3/4	9	20	254	1356		Center Blade		54	
			<b>4T-3421</b>	7J-2850	7/8x2 3/4	9	25	254	1356		Center Blade		68	
			<b>4T-2916</b>	6J-9044	7/8x2 3/4	5	20	254	816		Lateral Blade		32	
			<b>4T-3420</b>	7J-2851	7/8x2 3/4	5	25	254	816		Lateral Blade		41	
			<b>3G-8293/4</b>	5J-8767/8	7/8x2 3/4	7	22				HC End Bit		27	
			<b>3G-8315/6</b>		7/8x2 3/4	7	25				HC End Bit		30	
<b>D7H</b>	7U	5SB1-UP	<b>4T-7110</b>	5J-8767/8	7/8x2 3/4	6	20	25	987		Center Blade	2	4	
			<b>7T-6591</b>		7/8x2 3/4	6	25	279	987		Center Blade	2	55	
			<b>4T-7109</b>		7/8x2 3/4	4	20	254	567		Lateral Blade		22	
			<b>7T-6592</b>		7/8x2 3/4	4	25	279	567		Lateral Blade		31	
			<b>3G-8293/4</b>		7/8x2 3/4	7	22				HC End Bit		27	
			<b>3G-8315/6</b>		7/8x2 3/4	7	25				HC End Bit		30	
<b>D8</b>	8S	8A, 12C, 18C, 32D, 44C1-1192 86D, 3E	<b>5J-6865</b>	1J-9	3/4x3	26	20	254	2638		Center Blade		105	
			<b>4T-2944</b>	5J-6887	3/4x3	13	20	254	1318		Center Blade	2	52	
			<b>5J-6829</b>	1J-0013	3/4x3	26	25	254	2638		Center Blade		133	
			<b>4T-2860</b>	5J-6835	3/4x3	13	25	254	1318		Center Blade	2	66	
			<b>4T-6671</b>	5J-6929	3/4x3 1/4	8	30	254	400		Flat End Bit		24	
			<b>4T-6672</b>	5J-6930	3/4x4 1/2	6	30	254	400		Flat End Bit		24	
			<b>3J-2463/4</b>	3J-2463/4	3/4x3 1/4	7	25				F End Bit		28	
			<b>3G-8311/12</b>		3/4x4 1/2	7	30				HC End Bit		28	
		44C1193-UP 73D	<b>5J-6848</b>	1J-2668	3/4x3	28	25	254	2842		Center Blade		143	
			<b>4T-2862</b>	5J-6834	3/4x3	14	25	254	1419		Center Blade	2	71	
			<b>3J-2463/4</b>	3J-2463/4	3/4x3 1/4	7	25				F End Bit		28	
			<b>3G-8311/12</b>		3/4x4 1/2	7	30				HC End Bit		28	





















	Type	Serie	Ref.		Inches		mm.				Description	n°			
			Present	Old		n°									
		78C, 29E, 94E	<b>4T-6531</b>	5J-6831	7/8x3	10	25	254	1521		Center Blade	2	77		
			<b>4T-6531 HD</b>	5J-6831 HD	7/8x3	10	30	254	1521		Center Blade	2	90		
			<b>4T-6299</b>	3G-3798	7/8x3	10	35	254	1521		Center Blade	2	105		
		69E, 14J, 44K, 47K	<b>4J-8849/50</b>		7/8x3	7	28				F End Bit		27		
			<b>3G-8299/8300</b>	5J-8769/70	7/8x3	7	30				HC End Bit		27		
			<b>3G-8277/78</b>	7J-3459/60	7/8x3	7	40				HC End Bit		37		
			<b>4T-3418</b>	6J-7116	7/8x3	10	25	254	1534		Center Blade	2	77		
			<b>4T-3418 HD</b>	6J-7116 HD	7/8x3	10	30	254	1534		Center Blade	2	91		
			<b>4T-6298</b>	3G-3807	7/8x3	10	35	254	1534		Center Blade	2	106		
		29V	<b>4J-8849/50</b>		7/8x3	7	28				F End Bit		27		
			<b>3G-8299/8300</b>	5J-8769/70	7/8x3	7	30				HC End Bit		27		
			<b>3G-8277/78</b>	7J-3459/60	7/8x3	7	40				HC End Bit		37		
			<b>4T-2988</b>	8J-8118	1x3 1/4	7	25	254	1033		Center Blade	3	52		
			<b>1U-4933</b>	8J-8118 HD	1x3 1/4	7	30	254	1033		Center Blade	3	61		
			<b>4T-6301</b>	3G-3979	1x3 1/4	7	35	254	1033		Center Blade	3	72		
		29V1-UP	<b>9J-1479/80</b>		1x3 1/4	7	30				F End Bit		27		
			<b>3G-8301/2</b>	8J-8116/17	1x3 1/4	7	30				HC End Bit		27		
			<b>3G-8279/80</b>	9J-1472/3	1x3 1/4	7	40				HC End Bit		37		
			<b>9W-8651</b>		1x3 1/4	7	50				HC End Bit		47		
			<b>7T-4353</b>		1x3 1/2	7	45	330	1033		Center Blade	3	120		
			<b>7T-4088/9</b>		1x3 1/2	7					EWL End Bit		66		
		<b>D8L</b>	8S	4Y1-1939	<b>4T-3423</b>	6J-9606	1x3 1/2 **	6	25	254	857		Center Blade	2	43
					<b>4T-3417</b>	3G-6289	1x3 1/2 **	5	25	254	810		Center Blade	2	41
					<b>1U-4930</b>		1x3 1/2 **	6	30	254	857		Center Blade	2	51
					<b>1U-4929</b>		1x3 1/2 **	5	35	254	810		Center Blade	2	56
					<b>4T-3445</b>	1U-4295	1x3 1/2 **	6	35	254	857		Center Blade	2	59
					<b>4T-6302</b>	1U-4293	1x3 1/2 **	5	40	254	810		Center Blade	2	64
4Y1-1939	<b>9J-1477/8</b>				1x3 1/2**	7	28				F End Bit		28		
	<b>3G-8317/8</b>			8J-8119/20	1x3 1/2**	7	30				HC End Bit		28		
	<b>3G-8287/8</b>			9J-1474/5	1x3 1/2**	7	40				HC End Bit		38		
	<b>9W-8653/4</b>				1x3 1/2**	7	50				HC End Bit		48		
	<b>7T-5235</b>				1x3 1/2	6	45	330	856		Center Blade	2	99		
	<b>7T-4346</b>				1x3 1/2	5	45	330	810		Center Blade	1	94		
	<b>7T-4345</b>				1x3 1/2	5	45	330	810		Center Blade	1	94		
	<b>7T-4090/1</b>				1x3 1/2	7	0				EWL End Bit		68		
4Y1940-UP Excepto 4Y1968, 4Y1969, 4Y2011 y 4Y2055 - 4Y2087	<b>4T-9586</b>				1x3 1/4	11	30	330	1699		Center Blade	1	131		
	<b>4T-9587</b>				1x3 1/4	5	30	330	797		Center Blade	2	62		
	<b>4T-9836</b>				1x3 1/4	11	35	356	1699		Center Blade	1	165		
	<b>4T-9838</b>				1x3 1/4	5	35	330	797		Center Blade	2	72		
	<b>4T-9836 HD</b>				1x3 1/4	11	35	330	1699		Center Blade	1	153		
	<b>4T-9838 HD</b>				1x3 1/4	5	35	330	797		Center Blade	2	72		
	<b>4J-8723/4</b>				1x5 1/2	7	32				F End Bit		43		
	<b>3G-8291/2</b>			7J-6711/2	1x5 1/2	7	35				HC End Bit		60		
	<b>3G-8283/4</b>			7J-3463/4	1x5 1/2	7	40				HC End Bit		65		
	<b>9W-6192/3</b>				1x5 1/2	7	50				HC End Bit		70		
<b>D8</b>	8A	7A, 18C, 33D, 72D, 87D, 99D, 7E, 22E	<b>5J-6886</b>	1J-11	3/4x3	32	20	254	3248		Center Blade		129		
			<b>4T-2943</b>	5J-6890	3/4x3	16	20	254	1622		Center Blade	2	64		
			<b>5J-6852</b>	1J-12	3/4x3	32	25	254	3248		Center Blade		163		
			<b>4T-2888</b>	5J-6851	3/4x3	16	25	254	1622		Center Blade	2	82		
			<b>3J-2465/6</b>	1J-0979/80	3/4x4 1/2	7	28				F End Bit		28		

	Type	Serie	Ref.			Inches	mm.							Description	n°	
			Present	Old			n°									
			<b>3G-8313/4</b>			3/4x4 1/2	7	30						HC End Bit		28
		28E1-11125	<b>5J-6833</b>	2J-1487		7/8x3	3	25	254	1826				Center Blade	2	92
			<b>5J-5833 HD</b>	2J-1487 HD		7/8x3	3	30	254	1826				Center Blade	2	109
			<b>4T-6532</b>	5J-6832		7/8x3	3	25	254	911				Center Blade	4	45
			<b>4T-6532 HD</b>	5J-6832 HD		7/8x3	3	30	254	911				Center Blade	4	54
			<b>4T-6296</b>	3G-3808		7/8x3	3	35	254	911				Center Blade	4	63
			<b>4J-8843/4</b>			7/8x3	7	28					F End Bit		28	
			<b>3G-8315/6</b>	5J-8767/8		7/8x3	7	30					HC End Bit		30	
			<b>3G-8285/6</b>	7J-3457/8		7/8x3	7	40					HC End Bit		38	
		28E11126 - UP, 93E, 14F	<b>4T-2994</b>	8J-9668		1x3 1/4	8	25	254	1213				Center Blade	3	61
			<b>4T-2994 HD</b>	8J-9668 HD		1x3 1/4	8	30	254	1213				Center Blade	3	72
			<b>4T-3447</b>	3G-3982		1x3 1/4	8	35	254	1213				Center Blade	3	84
			<b>9J-1477/8</b>			1x3 1/2**	7	28						F End Bit		28
			<b>3G-8317/8</b>	8J-8119/20		1x3 1/2**	7	30						HC End Bit		28
			<b>3G-8287/8</b>	9J-1474/5		1x3 1/2**	7	40						HC End Bit		38
			<b>9W-8653/4</b>			1x3 1/2**	7	50						HC End Bit		48
			<b>7T-4351</b>			1x3 1/2	8	45	330	1214				Center Blade	3	141
			<b>7T-4090/1</b>			1x3 1/2	7							EWL End Bit		68
<b>D8L</b>	8A		5Y1-UP	<b>4T-2987</b>	8J-9565		1x3 1/2 **	6	25	254	921				Center Blade	2
			<b>4T-2988</b>	8J-8118		1x3 1/2 **	7	25	254	1033				Center Blade	2	52
			<b>1U-4932</b>			1x3 1/2 **	6	30	254	921				Center Blade	2	55
			<b>1U-4933</b>			1x3 1/2 **	7	30	254	1033				Center Blade	2	61
			<b>4T-6303</b>	3G-3980		1x3 1/2 **	6	35	254	921				Center Blade	2	64
			<b>4T-6301</b>	3G-3979		1x3 1/2 **	7	35	254	1033				Center Blade	2	72
			<b>9J-1477/8</b>			1x3 1/2**	7	28					F End Bit		28	
			<b>3G-8317/8</b>	8J-8119/20		1x3 1/2**	7	30					HC End Bit		28	
			<b>3G-8287/8</b>	9J-1474/5		1x3 1/2**	7	40					HC End Bit		38	
			<b>9W-8653/4</b>			1x3 1/2**	7	50					HC End Bit		48	
			<b>7T-4353</b>			1x3 1/2	7	45	330	1033			Center Blade	2	120	
			<b>7T-4352</b>			1x3 1/2	6	45	330	922			Center Blade	2	107	
			<b>7T-4090/1</b>			1x3 1/2	7						EWL End Bit		68	
<b>D8</b>	8U	11C, 74D, 88D, 24E	<b>4T-3419</b>	5J-6892		3/4x2	12	25	254	1213				Center Blade		61
			<b>4T-2861</b>	5J-6854		3/4x3	9	25	254	908				Lateral Blade		46
			<b>3J-2465/6</b>	1J-0979/80		3/4x4 1/2	7	28					F End Bit		28	
			<b>3G-8313/4</b>			3/4x4 1/2	7	30					HC End Bit		28	
		30E, 73E	<b>4T-6513</b>	5J-6894		7/8x3	10	25	254	1521				Center Blade		77
			<b>4T-6513 HD</b>	5J-6894 HD		7/8x3	10	30	254	1521				Center Blade		90
			<b>4T-6300</b>	3G-3977		7/8x3	10	35	254	1521				Center Blade		105
			<b>4T-6532</b>	5J-6832		7/8x3	6	25	254	911				Lateral Blade		46
			<b>4T-6532 HD</b>	5J-6832 HD		7/8x3	6	30	254	911				Lateral Blade		54
			<b>4T-6296</b>	3G-3808		7/8x3	6	35	254	911				Lateral Blade		63
			<b>4J-8843/4</b>			7/8x3	7	28						F End Bit		28
			<b>3G-8315/6</b>	5J-8767/8		7/8x3	7	30						HC End Bit		30
			<b>3G-8285/6</b>	7J-3457/8		7/8x3	7	40						HC End Bit		38
		20F, 45K, 48K	<b>4T-6513</b>	5J-6894		7/8x3	10	25	254	1521				Center Blade		77
			<b>4T-6513 HD</b>	5J-6894 HD		7/8x3	10	30	254	1521				Center Blade		90
			<b>4T-6300</b>	3G-3977		7/8x3	10	35	254	1521				Center Blade		105
			<b>4T-6512</b>	6J-9284		7/8x3	6	30	76	203				Lateral Blade		4
			<b>4T-6512 HD</b>	6J-9284 HD		7/8x3	6	30	254	924				Lateral Blade		55
			<b>4T-6297</b>	3G-3978		7/8x3	6	35	254	924				Lateral Blade		64















	Type	Serie	Ref.		Inches		mm.				Description	n°					
			Present	Old		n°											
			<b>4J-8843/4</b>		7/8x3	7	28				F End Bit		28				
			<b>3G-8315/6</b>	5J-8767/8	7/8x3	7	30				HC End Bit		30				
			<b>3G-8285/6</b>	7J-3457/8	7/8x3	7	40				HC End Bit		38				
			30V	<b>4T-2986</b>	8J-9564	1x3 1/4	5	25	254	781			Center Blade		39		
				<b>4T-2986 HD</b>	8J-9564 HD	1x3 1/4	5	30	254	781			Center Blade		46		
						<b>4T-6295</b>	3G-3981	1x3 1/4	5	35	254	781		Center Blade		54	
						<b>4T-2987</b>	8J-9565	1x3 1/4	6	30	25	102			Lateral Blade		1
						<b>4T-2987 HD</b>	1U-4932	1x3 1/4	6	30	254	921			Lateral Blade		55
						<b>4T-6303</b>	3G-3980	1x3 1/4	6	35	254	921			Lateral Blade		64
						<b>9J-1477/8</b>		1x3 1/2**	7	28				F End Bit		28	
<b>3G-8317/8</b>	8J-8119/20	1x3 1/2**				7	30				HC End Bit		28				
<b>3G-8287/8</b>	9J-1474/5	1x3 1/2**				7	40				HC End Bit		38				
<b>9W-8653/4</b>		1x3 1/2**				7	50				HC End Bit		48				
30V-UP	<b>7T-4352</b>					1x3 1/2	6	45	330	922			Center Blade	2	107		
	<b>7T-4350</b>					1x3 1/2	5	45	330	779			Lateral Blade		90		
	<b>7T-4349</b>		1x3 1/2	5	45	330	779			Lateral Blade		90					
	<b>7T-4090/1</b>		1x3 1/2	7					EWL End Bit		68						
<b>D8L</b>	8U	6Y1-1395	<b>4T-3422</b>	3G-1041	1x3 1/2**	7	25	254	1092		Center Blade	2	55				
			<b>1U-4931</b>	1U-4931	1x3 1/2**	7	30	254	1092			Center Blade	2	65			
			<b>4T-3446</b>	1U-4294	1x3 1/2**	7	35	254	1092			Center Blade	2	76			
			<b>4T-3417</b>	3G-6289	1x3 1/2**	5	25	254	810			Lateral Blade		41			
			<b>1U-4929</b>	1U-4929	1x3 1/2**	5	30	254	810			Lateral Blade		48			
			<b>4T-6302</b>	1U-4293	1x3 1/2**	5	35	254	810			Lateral Blade		56			
			<b>9J-1477/8</b>		1x3 1/2**	7	28				F End Bit		28				
			<b>3G-8317/8</b>	8J-8119/20	1x3 1/2**	7	30				HC End Bit		28				
			<b>3G-8287/8</b>	9J-1474/5	1x3 1/2**	7	40				HC End Bit		38				
			<b>9W-8653/4</b>		1x3 1/2**	7	50				HC End Bit		48				
	6Y1396-UP	<b>7T-4347</b>		1x3 1/2	7	45	330	1094			Center Blade	2	127				
		<b>7T-4346</b>		1x3 1/2	5	45	330	810			Right End Blade		94				
		<b>7T-4345</b>		1x3 1/2	5	45	330	810			Left End Blade		94				
		<b>7T-4090</b>		1x3 1/2	7					EWL End Bit		68					
		<b>4T-9590</b>		1x3 1/4	14	30	330	2165			Center Blade		167				
		<b>4T-9837</b>		1x3 1/4	14	35	330	2165			Center Blade		195				
		<b>4T-9587</b>		1x3 1/4	5	30	330	797			Lateral Blade		62				
		<b>4T-9838</b>		1x3 1/4	5	35	330	797			Lateral Blade		72				
		<b>4J-8723/4</b>		1x5 1/2	7	32				F End Bit		43					
		<b>3G-8291/2</b>	7J-6711/2	1x5 1/2	7	35				HC End Bit		60					
<b>3G-8283/4</b>	7J-3463/4	1x5 1/2	7	40				HC End Bit		65							
	<b>9W-6192/3</b>		1x5 1/2	7	50				HC End Bit		70						
<b>D8</b>	8R	62E, 43K	<b>4T-3418</b>	6J-7116	7/8x3	10	25	254	1534		Center Blade	2	77				
			<b>4T-3418 HD</b>	6J-7116 HD	7/8x3	10	30	254	1534			Center Blade	2	91			
			<b>3G-3807</b>		7/8x3	10	35	254	1534			Center Blade	2	106			
	8C	71F, 77G	<b>4T-2867</b>	5J-6809	7/8x3	13	25	254	2042		Center Blade		103				
			<b>4T-2867 HD</b>	5J-6809 HD	7/8x3	13	30	254	2042			Center Blade		121			
			<b>4J-8843/4</b>		7/8x3	7	28				F End Bit		28				
<b>3G-8315/6</b>	5J-8767/8	7/8x3	7	30				HC End Bit		30							
	<b>3G-8285/6</b>	7J-3457/8	7/8x3	7	40				HC End Bit		38						
<b>D9</b>	9S	21E1-831, 25E	<b>5J-6802</b>	1J-0019	1 x 4	21	30	305	3239		Center Blade		231				
			<b>4T-6459</b>	5J-6806	1 x 4	9	30	305	1327			Center Blade	1	95			
			<b>4T-6456</b>	5J-6800	1 x 4	6	30	305	953			Center Blade	2	68			





















	Type	Serie	Ref.		Inches	n°	mm.				Description	n°	
			Present	Old									
			<b>8J-7142</b>	8J-7142	1 x 4	9	35	305	1327		Center Blade	1	110
			<b>8J-7148</b>	8J-7148	1 x 4	6	35	305	953		Center Blade	2	79
			<b>4T-2327</b>		1 x 4	9	35	330	1327		Center Blade	1	120
			<b>4T-2329</b>		1 x 4	6	35	330	953		Center Blade	2	86
			<b>7J-2961</b>	7J-2961	1 x 4	9	40	305	1327		Center Blade	1	126
			<b>7J-2960</b>	7J-2960	1 x 4	6	40	305	953		Center Blade	2	91
			<b>5J-1279/80</b>		1x3 1/2	7	32				F End Bit		43
			<b>3G-8289/90</b>	7J-6713/4	1x5 1/2	7	35				HC End Bit		60
			<b>3G-8281/2</b>	7J-3461/2	1x3 1/2	7	40				HC End Bit		65
			<b>9W-9193/4</b>		1x5 1/2	7	50				HC End Bit		70
		53C, 89D, 21E832-UP	<b>4T-6448</b>	5J-6803	1x3 1/2	10	30	305	1521		Center Blade	2	108
			<b>4T-2324</b>		1x3 1/2	10	35	330	1521		Center Blade	2	137
			<b>7J-2962</b>		1x3 1/2	10	40	305	1521		Center Blade	2	145
			<b>5J-1279/80</b>		1x3 1/2	7	32				F End Bit		43
			<b>3G-8289/90</b>	7J-6713/4	1x5 1/2	7	35				HC End Bit		60
			<b>3G-8281/2</b>	7J-3461/2	1x3 1/2	7	40				HC End Bit		65
			<b>9W-9193/4</b>		1x5 1/2	7	50				HC End Bit		70
		5A, 18K, 46K	<b>4T-2310</b>	1U-4941	1x3 1/2**	7	30	330	1038		Center Blade	3	80
			<b>4T-2334</b>	8J-7155	1x3 1/2**	7	35	330	1038		Center Blade	3	94
			<b>7J-2980</b>		1 x 4	7	40	330	1038		Center Blade	3	107
			<b>5J-1279/80</b>		1x3 1/2	7	32				F End Bit		43
			<b>3G-8289/90</b>	7J-6713/4	1x5 1/2	7	35				HC End Bit		60
			<b>3G-8281/2</b>	7J-3461/2	1x3 1/2	7	40				HC End Bit		65
			<b>9W-9193/4</b>		1x5 1/2	7	50				HC End Bit		70
<b>D9L</b>	9S	18Y1-1875, 52Y1-UP	<b>4T-6386</b>	6J-2084	1x3 1/2	7	30	330	1038		Center Blade	1	80
			<b>4T-2310</b>	1U-4941	1x3 1/2								0
			<b>4T-6385</b>	3G-7762	1x3 1/2	8	30	330	1219		Center Blade	2	94
			<b>4T-2309</b>	1U-4942	1x3 1/2								0
			<b>4T-2334</b>	8J-7155	1x3 1/2	7	35	330	1038		Center Blade	1	94
			<b>4T-2333</b>	1U-1560	1x3 1/2	8	35	330	1219		Center Blade	2	110
			<b>7J-2980</b>		1x3 1/2	7	40	330	1038		Center Blade	1	107
			<b>1U-1560 HD</b>		1x3 1/2	8	40	330	1219		Center Blade	2	126
			<b>1U-1545</b>		1 1/4x4	7	40				HC End Bit		66
			<b>1U-1546</b>		1 1/4x4	7	40				HC End Bit		66
			<b>8E-4198</b>		1 1/4x4	7	55				HC End Bit		90
			<b>8E-4199</b>		1 1/4x4	7	55				HC End Bit		90
			<b>7T-4688</b>		1 1/4x4	7	60				HC End Bit		99
			<b>7T-4689</b>		1 1/4x4	7	60				HC End Bit		99
			<b>7T-4342</b>		1x3 3/4	7	45	406	1039		Center Blade	1	148
			<b>7T-6788</b>		1x3 3/4	8	45	406	1222		Center Blade	1	174
			<b>7T-6787</b>		1x3 3/4	8	45	406	1222		Center Blade	1	174
		18Y-1876-UP	<b>7T-9782</b>		1 1/4x4	6	35	406	908		Center Blade	2	101
			<b>7T-9779</b>		1 1/4x4	5	35	406	832		Center Blade	2	92
			<b>7T-4689/9</b>		1 1/4x4	7					HC End Bit		106
		90F	<b>4T-6450</b>	5J-6836	1 x 4	15	30	305	2210		Center Blade		158
			<b>5J-1279/80</b>		1x3 1/2	7	32				F End Bit		43
			<b>3G-8289/90</b>	7J-6713/4	1x5 1/2	7	35				HC End Bit		60
			<b>3G-8281/2</b>	7J-3461/2	1x3 1/2	7	40				HC End Bit		65
			<b>9W-9193/4</b>		1x5 1/2	7	50				HC End Bit		70
	9A	52C, 90D,	<b>5J-6801</b>	1J-20	1 x4	25	30	305	3794		Center Blade		271

















	Type	Serie	Ref.		Inches		mm.				Description	n°		
			Present	Old		n°								
		11E, 26E	<b>4T-6388</b>	5J-6805	1 x4	7	30	330	1064		Center Blade	1	82	
			<b>4T-6387</b>	5J-6804	1 x4	9	32	330	1368		Center Blade	2	112	
			<b>4T-2328</b>	8J-7153	1 x4	7	30	330	1064		Center Blade	1	82	
			<b>4T-2325</b>	8J-7152	1 x4	9	35	330	1368		Center Blade	2	123	
			<b>7J-2966</b>		1 x4	7	40	330	1064		Center Blade	1	110	
			<b>7J-2965</b>		1 x4	9	40	330	1368		Center Blade	2	141	
9U	55C	<b>4J-8723/4</b>		1x5 1/2	7	32				F End Bit		43		
		<b>3G-8291/2</b>	7J-6711/2	1x5 1/2	7	35				HC End Bit		60		
		<b>4T-6453</b>	5J-6893	1x3 1/4	13	35	305	1975		Center Blade		164		
		<b>8J-7150</b>		1x3 1/4	13	35	305	1975		Center Blade		164		
		<b>4T-2331</b>		1x3 1/4	13	35	330	1975		Center Blade		178		
		<b>7J-2963</b>		1x3 1/4	13	40	305	1975		Center Blade		188		
		<b>4T-6457</b>	5J-6837	1x3 1/4	6	30	305	908		Lateral Blade		65		
		<b>8J-7151</b>		1x3 1/4	6	35	305	908		Lateral Blade		76		
		<b>4T-2330</b>		1x3 1/4	6	35	330	908		Lateral Blade		82		
		<b>7J-2964</b>		1x3 1/4	6	40	305	908		Lateral Blade		86		
		<b>4J-8723/4</b>		1x5 1/2	7	32				F End Bit		43		
		<b>3G-8291/2</b>	7J-6711/2	1x5 1/2	7	35				HC End Bit		60		
		<b>3G-8283/4</b>	7J-3463/4	1x5 1/2	7	40				HC End Bit		65		
		<b>8E-4196/7</b>		1x5 1/2	7	50				HC End Bit		70		
		9U SxS	50E, 20H	<b>4T-6378</b>	6J-5945	1x3 1/4**	6	30	330	899		Center Blade	4	69
				<b>4T-6377</b>	8J-2126	1x3 1/4**	4	30	330	586		Center Blade	3	45
				<b>4T-6379</b>	6J-6144	1x3 1/4**	4	30	330	587		Center Blade	2	45
				<b>4T-2332</b> <b>4T-9558</b>	8J-7141	1x3 1/4**	6	35	330	899		Center Blade	4	81
<b>8J-2126 HD</b>				1x3 1/4**	4	35	330	586		Center Blade	3	53		
<b>4T-2326</b> <b>4T-9550</b>	8J-7154			1x3 1/4	4	35	330	587		Center Blade	2	53		
<b>4J-8723/4</b>				1x5 1/2	7	32				F End Bit		43		
<b>3G-8291/2</b>	7J-6711/2			1x5 1/2	7	35				HC End Bit		60		
<b>3G-8283/4</b>	7J-3463/4			1x5 1/2	7	40				HC End Bit		65		
<b>8E-4196/7</b>				1x5 1/2	7	50				HC End Bit		70		
9U	14C, 19K	<b>4T-6378</b>	6J-5945	1x3 1/4**	6	30	330	899		Center Blade	1	69		
		<b>4T-6379</b>	5J-6144	1x3 1/4**	4	30	330	587		Center Blade	2	45		
		<b>4T-2332</b> <b>4T-9558</b>	8J-7141	1x3 1/4**	6	35	330	899		Center Blade	1	81		
		<b>4T-2326</b> <b>4T-9550</b>	8J-7154	1x3 1/4**	4	35	330	587		Center Blade	2	53		
		<b>7J-2959 D</b>		1x3 1/4**	6	40	330	899		Center Blade	1	93		
		<b>7J-2979</b>		1x3 1/4**	4	40	330	587		Center Blade	2	61		
		<b>4T-6378</b>	6J-5945	1x3 1/4**	6	30	330	899		Lateral Blade		69		
		<b>4T-2332</b> <b>4T-9558</b>	8J-7141	1x3 1/4**	6	35	330	899		Lateral Blade		81		
		<b>7J-2959 D</b>		1x3 1/4**	6	40	330	899		Lateral Blade		93		
		<b>4J-8723/4</b>		1x5 1/2	7	32				F End Bit		43		
		<b>3G-8291/2</b>	7J-6711/2	1x5 1/2	7	35				HC End Bit		60		
		<b>3G-8283/4</b>	7J-3463/4	1x5 1/2	7	40				HC End Bit		65		
		<b>8E-4196/7</b>		1x5 1/2	7	50				HC End Bit		70		
		<b>D9L</b>	9U	19Y1-1474	<b>4T-6381</b>	1U-4943	1x3 1/2	9	30	330	1348		Center Blade	2
<b>4T-2323</b> <b>4T-9547</b>	1U-1561				1x3 1/2	9	35	330	1348		Center Blade	2	121	

	Type	Serie	Ref.			Inches	mm.				Description	n°				
			Present	Old			n°									
			<b>4T-2323HD</b> <b>4T-9547HD</b>	1U-1561 HD	1x3 1/2	9	40	330	1348		Center Blade	2	139			
			<b>4T-6382</b>	1U-4944	1x3 1/2	6	30	330	635		Lateral Blade		49			
			<b>4T-2322</b> <b>4T9546</b>	1U-1562	1x3 1/2	6	35	330	635		Lateral Blade		57			
			<b>4T-2322HD</b> <b>4T-9546HD</b>	1U-1562 HD	1x3 1/2	6	40	330	635		Lateral Blade		65			
			<b>1U-1545/6</b>		1 1/4x4	7	40					HC End Bit		66		
			<b>8E-4198/9</b>		1 1/4x4	7	55					HC End Bit		90		
			<b>7T-4688/9</b>		1 1/4x4	7	60					HC End Bit		99		
			<b>7T-4335</b>		1x3 3/4	9	45	406	1353			Center Blade	2	193		
			<b>7T-4343</b>		1x3 3/4	6	45	406	635			Right End Blade		91		
			<b>7T-4344</b>		1x3 3/4	6	45	406	635			Left End Blade		91		
			<b>7T-4096/7</b>		1 1/4x4	7						HC End Bit		108		
				19V1475-UP	<b>9W-775</b>		1 1/4x4	5	35	406	756		Center Blade	3	84	
					<b>7T-9781</b>		1 1/4x4	5	35	406	879		Lateral Blade		98	
					<b>7T-4688/9</b>		1 1/4x4	7					HC End Bit		106	
			<b>D9</b>	9C	70F, 45G, 20Y1-UP	<b>4T-6450</b>	5J-6836	1 x 4	15	30	305	2210		Center Blade	2	158
<b>4T-6388</b>	5J-6805	1 x 4				7	30	330	1064		Lateral Blade	82				
<b>4J-8723/4</b>		1x5 1/2				7	32					F End Bit	43			
<b>3G-8291/2</b>	7J-6711/2	1x5 1/2				7	35					HC End Bit	60			
<b>3G-8283/4</b>	7J-3463/4	1x5 1/2				7	40					HC End Bit	65			
<b>8E-4196/7</b>		1x5 1/2				7	50					HC End Bit	70			
	9R	63E, 39K		<b>4T-6386</b> <b>4T-2310</b>	6J-2084 1U-4941	1x3 1/4**	7	30	330	1038		Center Blade	3	80		
<b>4T-2334</b>				8J-7155	1x3 1/4**	7	35	330	1038		Center Blade	3	94			
<b>7J-2980</b>					1 x 4**	7	40	330	1038		Center Blade	3	107			
<b>D10</b>	10S	79W368-UP	<b>3G-0394</b>		1 1/4x4	9	40	330	1029		Center Blade	2	106			
			<b>3G-0393</b>		1 1/4x4	9	40	330	1026		Center Blade	2	106			
			<b>1U-4455</b>		1 1/4x4	9	35	400	1029		Center Blade	2	112			
			<b>1U-4459</b>		1 1/4x4	9	35	400	1026		Center Blade	2	112			
			<b>4T-0081</b>		1 1/4x4	9	40	400	1029		Center Blade	2	128			
			<b>4T-0082</b>		1 1/4x4	9	40	400	1026		Center Blade	2	128			
			<b>6Y-0016</b>		1 1/4x4	9	45	400	1029		Center Blade	2	144			
			<b>6Y-0017</b>		1 1/4x4	9	45	400	1026		Center Blade	2	144			
			<b>4T-0604</b>		1 1/4x4	9	50	400	1029		Center Blade	2	160			
			<b>4T-0607</b>		1 1/4x4	9	50	400	1026		Center Blade	2	160			
			<b>6Y-0021</b>		1 1/4x4	9	60	400	1029		Center Blade	2	193			
			<b>6Y-0020</b>		1 1/4x4	9	60	400	1026		Center Blade	2	192			
			<b>8E-4543/4</b>	9W-3674/5	1 1/4x4	9	60					HC End Bit		147		
			<b>8E-4545/6</b>		1 1/4x4	9	60					EWL End Bit		147		
				1RH		<b>9W-6608</b>		1 1/4x4	5	35	400	859		Center Blade	2	94
			<b>9W-6609</b>				1 1/4x4	6	35	400	992		End Blade	2	108	
			<b>9W-6657</b>				1 1/4x4	5	45	400	859		Center Blade	2	121	
			<b>9W-6656</b>				1 1/4x4	6	45	400	992		End Blade	2	139	
	<b>8E-2086</b>		1 1/4x4			5	60	400	859		End Blade	2	161			
	<b>8E-2085</b>		1 1/4x4			6	60	400	992		End Blade	2	187			
	<b>8E-4543/4</b>	9W-3674/5	1 1/4x4			9	60					HC End Bit		147		
	<b>8E-4545/6</b>		1 1/4x4			9	60					EWL End Bit		147		
		10U	80W360-UP	<b>3G-0396</b>		1 1/4x4	9	40	330	1060		Center Blade	3	109		
	<b>3G-0395</b>				1 1/4x4	7	40	330	779		Lateral Blade		80			
	<b>4T-0083</b>			1U-4458	1 1/4x4	9	40	400	1060		Center Blade	3	132			

	Type	Serie	Ref.		Inches		mm.				Description	n°	
			Present	Old		n°							
			<b>4T-0084</b>	1U-4457	1 1/4x4	7	40	400	779		Lateral Blade		97
			<b>6Y-0018</b>		1 1/4x4	9	45	400	1060		Center Blade	3	149
			<b>6Y-0019</b>		1 1/4x4	7	45	400	779		Lateral Blade		109
			<b>4T-0609</b>		1 1/4x4	9	50	381	1060		Center Blade	3	158
			<b>4T-0608</b>		1 1/4x4	7	50	400	779		Lateral Blade		122
			<b>6Y-0023</b>		1 1/4x4	9	60	381	1060		Center Blade	3	189
			<b>6Y-0022</b>		1 1/4x4	7	60	400	779		Lateral Blade		146
			<b>8E-4543/4</b>	9W-3674/5	1 1/4x4	9	60				HC End Bit		147
			<b>8E-4545/6</b>		1 1/4x4	9	60				EWL End Bit		147
		1SH	<b>9W-6608</b>		1 1/4x4	5	35	400	859		Center Blade	3	94
			<b>9W-6609</b>		1 1/4x4	6	35	400	992		End Blade	2	108
			<b>9W-6657</b>		1 1/4x4	5	45	400	859		Center Blade	3	121
			<b>9W-6656</b>		1 1/4x4	6	45	400	992		End Blade	2	139
			<b>8E-2086</b>		1 1/4x4	5	60	400	859		Center Blade	3	161
			<b>8E-2085</b>		1 1/4x4	6	60	400	992		End Blade	2	187
			<b>8E-4543/4</b>	9W-3674/5	1 1/4x4	9	60				HC End Bit		147
			<b>8E-4545/6</b>		1 1/4x4	9	60				EWL End Bit		147
			<b>D11 N</b>	11S	4BB, 4KB	<b>9W-2426</b>	9W-3674/5	1 1/4x4	9	45	406	1099	
<b>9W-2425</b>		9				45		406	1022		Center Blade	2	146
<b>8E-4543/4</b>	1 1/4x4	9				60					HC End Bit		147
<b>8E-4545/6</b>	1 1/4x4	9				60					EWL End Bit		147
<b>9W-4495</b>		9				60		406	1099		Center Blade	2	210
<b>9W-4494</b>		9				60		406	1022		Center Blade	2	195
<b>9W-4491/2</b>		9		75	0	0		HC End Bit		149			
11U	4CB, 5TB	<b>9W-2426</b>		9W-3674/5	1 1/4x4	9	45	406	1099		Center Blade	1	157
		<b>9W-2424</b>				9	45	406	1023		Center Blade	2	146
		<b>9W-2425</b>				9	45	406	1022		Lateral Blade		146
		<b>8E-4543/4</b>			1 1/4x4	9	60				HC End Bit		147
		<b>8E-4545/6</b>			1 1/4x4	9	60				EWL End Bit		147
		<b>9W-4495</b>			9	60	406	1099		Center Blade	1	210	
<b>9W-4493</b>		9	60	406	1026		Center Blade	2	196				
<b>9W-4494</b>		9	60	406	1022		Lateral Blade		195				
<b>9W-4491/2</b>		9	75				HC End Bit		149				



## Cutting Edges for Compactors

	Type	Serie	Ref		Inches	n°	mm.							Description	n°				
			Present	Old															
815	S	23K, 56D	<b>4T-2921</b>	7J-2363	7/8 x 3	7	19	254	1064					Center Blade	1	38			
			<b>4T-2922</b>	6J-5340	7/8 x 3	5	19	254	759						Center Blade	2	27		
			<b>4T-2993</b>	7J-9481	7/8 x 3	7	25	254	1064						Center Blade	1	51		
			<b>4T-2992</b>	7J-2847	7/8 x 3	5	25	254	759						Center Blade	2	37		
			<b>3G-8315/16</b>	5J-8767/8	7/8x2 3/4	7	30								HC End Bit		30		
			<b>3G-8285/86</b>	5J-8768	7/8x2 3/4	7	40								HC End Bit		40		
			<b>4T-3019</b>	7J-7669	7/8 x 3	5	19	203	1364						Skid Shoe	2	39		
			815	S	39S, 17Z	<b>4T-3012</b>	3G-975	3/4x2 1/4	10	19	203	1495					Center Blade	2	42
						<b>3G-8319/20</b>	5J-1419/20	3/4x2 1/4	6								HC End Bit		21
			815	F	24K1-1044 59E1-341	<b>5J-6897</b>	1J-3	5/8x2 1/4	29	19	203	2892					Center Blade	1	82
<b>4T-3008</b>	7J-9475	5/8x2 1/4				11	19	203	1165						Center Blade	1	33		
<b>4T-3020</b>	7J-9476	5/8x2 1/4				9	19	203	859						Center Blade	2	24		
<b>3G-8295/6</b>	9F-7075/6	5/8x2 1/4				6	0	0	0						HC End Bit		20		
<b>4T-3004</b>	9J-6853	3/4x2 1/2				9	19	203	1438						Center Blade	2	40		
815	F	24K1045-UP 59E342-UP	<b>3G-8297/8</b>	4J-8261/2	3/4x2 1/2	6							HC End Bit		19				
			<b>4T-3004</b>	9J-6853	3/4x2 1/2	9	19	203	1438					Center Blade	2	40			
816	Compactor	51K	<b>4T-6531</b>	5J-6831	7/8 x 3	10	25	254	1521					Center Blade	1	73			
			<b>4T-6532</b>	5J-6832	7/8 x 3	6	25	254	911						Center Blade	2	44		
			<b>4T-6531HD</b>	5J-6831HD	7/8 x 3	10	32	254	1521						Center Blade	1	92		
			<b>4T-6532HD</b>	5J-6832HD	7/8 x 3	6	32	254	911						Center Blade	2	54		
			<b>4T-6299</b>		7/8 x 3	10	38	254	1521						Center Blade	1	104		
			<b>4T-6296</b>		7/8 x 3	6	38	254	911						Center Blade	2	63		
			<b>3G-8315/16</b>	5J-8767/8	7/8x2 3/4	7	30								HC End Bit		30		
			<b>3G-8285/86</b>	5J-8768	7/8x2 3/4	7	40								HC End Bit		40		
			816	Compactor	41S, 15Z	<b>4T-2922</b>	6J-5340	7/8 x 3	5	19	254	759					Center Blade	1	27
						<b>4T-2923</b>	9J-5228	7/8 x 3	7	19	254	1029						Center Blade	2
816	Compactor		<b>4T-2992</b>	7J-2847	7/8 x 3	5	25	254	759					Center Blade	1	37			
			<b>4T-2923HD</b>	9J-5228HD	7/8 x 3	7	25	254	1029						Center Blade	2	49		
824	S	35G1-222	<b>5J-6891</b>	3J-7566	3/4x2 3/4	10	19	254	1562					Center Blade	2	55			
			<b>5J-6891HD</b>	3J-7566HD	3/4x2 3/4	10	25	254	1562						Center Blade	2	74		
			<b>3G-8315/16</b>	5J-8767/8	7/8x2 3/4	7	30								HC End Bit		30		
			<b>3G-8285/86</b>	5J-8768	7/8x2 3/4	7	40								HC End Bit		40		
			<b>7T-3491</b>	4J-4361	3/4 x 3	7	25	203	1111						Skid Shoe	3	43		
	824	F	93G	<b>4T-6514</b>	5J-6811	7/8x2 3/4	10	25	254	1562					Center Blade	2	74		
				<b>4T-6514HD</b>	5J-6811HD	7/8x2 3/4	10	32	254	1562						Center Blade	2	94	
		S	35G223-UP	<b>3G-8315/16</b>	5J-8767/8	7/8x2 3/4	7	30							HC End Bit		30		
				<b>3G-8285/86</b>	5J-8768	7/8x2 3/4	7	40								HC End Bit		40	
				<b>7T-3492</b>	5J-2827	7/8 x 3	7	25	203	1111						Skid Shoe	3	43	
816	S	88H	<b>4T-6448</b>	5J-6803	1 x 3 1/2	10	32	305	1521					Center Blade	2	101			
			<b>7J-2962</b>		1 x 3 1/2	10	41	305	1521						Center Blade	2	144		
834			<b>3G-8289/90</b>	7J-6713/14	1 x 3 1/2	7							HC End Bit		64				
834	C	64G	<b>4T-2889</b>	5J-6810	7/8 x 3	9	25	254	1410					Center Blade	2	67			
			<b>4T-2889HD</b>	5J-6810HD	7/8 x 3	9	32	254	1410						Center Blade	2	85		
			<b>3G-8315/16</b>	5J-8767/8	7/8x2 3/4	7	30								HC End Bit		30		
			<b>3G-8285/86</b>	5J-8768	7/8x2 3/4	7	40								HC End Bit		40		
			<b>4T-6645</b>	4J-5611	7/8 x 3	6	25	254	1410						Skid Shoe	2	68		



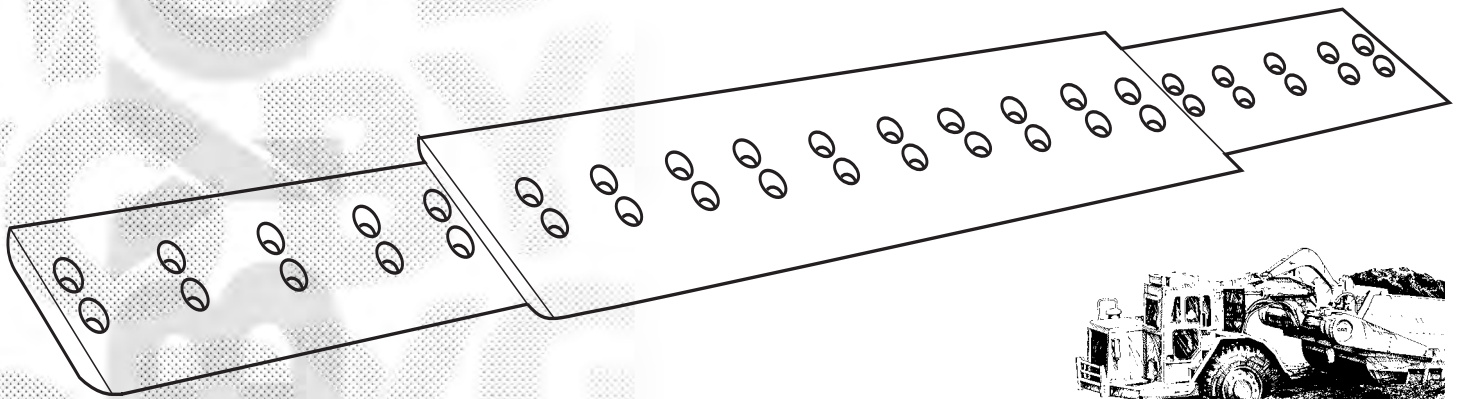





	Type	Serie	Ref.		Inches 	n°	mm.					Description	n°		
			Present	Old											
<b>824</b>	F "U"	93G	<b>4T-6531</b>	5J-6831	7/8 x 3	10	25	254	1521			Center Blade	2	73	
			<b>4T-3561HD</b>	5J-6831HD	7/8 x 3	10	32	254	1521			Center Blade	2	92	
			<b>4T-6299</b>	7J-2970 G-3798	7/8 x 3	10	38	254	1521			Center Blade	2	104	
			<b>4T-6532</b>	5J-6832	7/8 x 3	6	25	254	911			Int. Ends Std.		44	
			<b>4T-6532HD</b>	5J-3832HD	7/8 x 3	6	32	254	911			Int. Ends HD		54	
			<b>4T-6296</b>	7J-2972 3G-3808	7/8 x 3	6	38	254	911			Int. Ends Ext. Ser.		63	
			<b>3G-8315/16</b>	5J-8767/8	7/8x2 3/4	7	30					HC End Bit		30	
			<b>3G-8285/86</b>	5J-8768	7/8x2 3/4	7	40					HC End Bit		40	
<b>825</b>		89X	<b>4T-6238</b>	8J-8119	1 x 3	8	25	254	1200			Center Blade	3	56	
			<b>4T-6238HD</b>	8J-8119HD	1 x 3	8	32	254	1200			Center Blade	3	71	
			<b>3G-8317/18</b>	8J-8105/20	1 x 3	7	30					HC End Bit		30	
			<b>3G-8287/8</b>	9J-1474/5	1 x 3	7	40					HC End Bit		40	
<b>835</b> <b>834</b> <b>826</b>	F  S	27K  36G, 96G 97X, 90K	<b>4T-6515</b>	5J-6807	7/8x2 3/4	12	25	254	1775			Center Blade	2	85	
			<b>4T-6515HD</b>	5J-6807HD	7/8x2 3/4	12	32	254	1775			Center Blade	2	108	
			<b>3G-8315/16</b>	5J-8767/8	7/8x2 3/4	7	30					HC End Bit		30	
			<b>3G-8285/86</b>	5J-8768	7/8x2 3/4	7	40					HC End Bit		40	
				<b>4J-4367</b>		Weld On		19	133	406			R Shoe		5
				<b>4J-4368</b>		Weld On		19	133	406			L Shoe		5
				<b>4T-6650</b>	4J-4695	7/8x3	8	25	254	1162			Skid Shoe		56
				<b>4T-6651</b>	4J-4380	7/8x3	9	25	254	1318			Skid Shoe		63
<b>834</b>	U	14B	<b>4T-8797</b>	1U-1224	7/8x3	6	25	254	989			Center Blade	2	46	
			<b>4T-8797HD</b>	1U-1224HD	7/8x3	6	32	254	989			Center Blade	2	58	
			<b>4T-8798</b>	4T-3640	7/8x3	7	25	254	1076			Int. Ends Std.		51	
			<b>4T-8798HD</b>	4T-3640HD	7/8x3	7	32	254	1076			Int. Ends HD		64	
			<b>3G-8315/16</b>	5J-8767/8	7/8x2 3/4	7	30					HC End Bit		30	
			<b>3G-8285/86</b>	5J-8768	7/8x2 3/4	7	40					HC End Bit		40	
			<b>4T-6645</b>	4J-5611	7/8x3	6	25	254	1410			Skid Shoe	2	68	



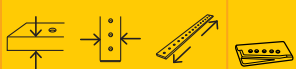





# Cutting Edges for Scraper













	Type	Serie	Ref.		Inches 	n°	mm.				Description		
			Present	Old									
<b>DW-10</b>	Curved Moldboard	3C	<b>4T-2882</b>	5J-6914	3/4x2 1/4	16	19	254	1.407		Center Blade	50	
			<b>4T-6626</b>	7J-3790	3/4x2 1/4	16	25	330	1.407		Center Blade	85	
	Curved Moldboard	<b>4T-2883</b>	5J-6913	3/4x2 1/4	6	19	254	514	Lateral Blade		18		
		<b>7J-3791</b>	5J-6907	3/4x2 1/4	6	19	305	511	Right End "flat cut"		20		
	<b>7J-3792</b>	5J-6908	3/4x2 1/4	5	19	305	511	Left End "flat cut"	20				
	<b>8F-7232</b>	4F-7838	3/4x2 1/4	5	19	203	406		End Bit		12		
<b>DW-15</b>	Straihg Moldboard	19C	<b>4T-2939</b>	5J-6840	7/8x2 1/2	15	25	254	2.324		Center Blade	111	
			<b>4T-2940</b>	5J-6843	7/8x2 1/2	7	25	254	1.073		Center Blade	51	
			<b>4T-6625</b>	7J-3697	7/8x2 1/2	7	25	330	1.073		Center Blade	66	
			<b>4T-2953</b>	5J-6841	7/8x2 1/2	4	25	254	622		Lateral Blade	29	
			<b>9F-1831</b>	4F-4357	5/8x2 1/2	4	16	203	356		End Bit	9	
	Straight Moldboard (old type)	4W, 92D	<b>4T-2947</b>	5J-6855	7/8x2 1/2	17	25	254	2.578		Center Blade	124	
			<b>4T-2941</b>	5J-6844	7/8x2 1/2	9	25	254	1.378		Center Blade	66	
			<b>4T-6627</b>	7J-3688	7/8x2 1/2	9	25	330	1.378		Center Blade	84	
			<b>4T-2942</b>	5J-6847	7/8x2 1/4	4	25	254	597		Lateral Blade	29	
			<b>8F-7232</b>	4F-7838	3/4x2 1/4	5	19	203	406			End Bit	12
<b>40</b>	Straight Moldboard	1W	<b>4T-2962</b>	5J-6813	3/4x2	10	16	203	1.022		Center Blade	22	
			<b>4T-2874</b>	5J-6946	3/4x2	10	19	254	1.022		Center Blade	36	
			<b>4T-2965</b>	5J-6814	3/4x2	4	16	203	394		Lateral Blade	8	
<b>60</b>	Curved Moldboard	1D	<b>4T-2881</b>	5J-6916	3/4x2 1/4	14	19	254	1.245		Center Blade	44	
			<b>4T-2884</b>	5J-6915	3/4x2 1/4	5	19	254	441		Lateral Blade	15	
			<b>7J-3795</b>	5J-6867	3/4x2 1/4	5	19	305	441		Right End "flat cut"	17	
	<b>7J-3796</b>	5J-6868	3/4x2 1/4	5	19	305	441	Left End "flat cut"	17				
	<b>9F-1831</b>	4F-4357	5/8x2 1/2	4	16	203	356	End Bit	9				
	Straight Moldboard	2W	<b>4T-2939</b>	5J-6840	7/8x2 1/2	15	25	254	2.324			Center Blade	111
<b>4T-2940</b>			5J-6843	7/8x2 1/2	7	25	254	1.073	Center Blade	51			
<b>4T-6625</b>			7J-3697	7/8x2 1/2	7	25	330	1.073	Center Blade	66			
<b>10</b>	Straight Moldboard	19C	<b>4T-2953</b>	5J-6841	7/8x2 1/2	4	25	254	622		Lateral Blade	29	
			<b>9F-1831</b>	4F-4357	5/8x2 1/2	4	16	203	356		End Bit	9	
			<b>4T-2962</b>	5J-6813	3/4x2	10	16	203	1.022		Center Blade	22	
<b>70</b>	Curved Moldboard	8C	<b>4T-2882</b>	5J-6914	3/4x2 1/4	16	19	254	1.407		Center Blade	50	
			<b>4T-3790</b>	7J-3790	3/4x2 1/4	16	25	330	1.407		Center Blade	85	
<b>10</b>	Curved Moldboard	3C	<b>4T-2883</b>	5J-6913	3/4x2 1/4	6	19	254	514		Lateral Blade	18	
			<b>7J-3791</b>	5J-6907	3/4x2 1/4	6	19	305	511		Right End "flat cut"	20	
			<b>7J-3792</b>	5J-6908	3/4x2 1/4	6	19	305	511		Left End "flat cut"	20	
			<b>8F-7232</b>	4F-7838	3/4x2 1/2	6	19	203	406			End Bit	12
			<b>4T-2882</b>	5J-6914	3/4x2 1/4	16	19	254	1.407		Center Blade	50	











	Type	Serie	Ref.		Inches 	n°	mm.				Description	
			Present	Old								
<b>70</b>	Straight Moldboard	3W, 91D	<b>4T-2947</b>	5J-6855	7/8x2 1/2	17	25	254	267		Center Blade	124
			<b>4T-2941</b>	5J-6844	7/8x2 1/2	9	25	254	1.378		Center Blade	66
			<b>4T-6627</b>	7J-3688	7/8x2 1/2	9	25	330	1.378		Center Blade	84
			<b>4T-2942</b>	5J-6847	7/8x2 1/2	4	25	254	597		Lateral Blade	29
			<b>8F-7232</b>	4F-7838	3/4x2 1/4	5	19	203	406		End Bit	12
<b>80</b>	Curved Moldboard	2D	<b>5J-6912</b>	2J-1202	7/8x2 1/2	17	19	330	1.511		Center Blade	71
			<b>4T-6622</b>	7J-3661	7/8x2 1/2	17	25	330	1.511		Center Blade	91
			<b>5J-6909</b>	2J-1197	7/8x2 1/2	17	32	305	1.511		Center Blade	100
			<b>4T-6624</b>	7J-3952	7/8x2 1/2	7	19	330	616		Lateral Blade	29
			<b>5J-6911</b>	2J-1201	7/8x2 1/2	7	32	305	616		Lateral Blade	41
			<b>4T-8805</b>	5J-6883	7/8x2 1/2	7	25	394	616		Right End "flat cut"	38
			<b>4T-8806</b>	5J-6884	7/8x2 1/2	7	25	394	616		Left End "flat cut"	38
			<b>8F-7232</b>	4F-7838	3/4x2 1/2	5	19	203	406		End Bit	12
			<b>1J-1299</b>		Soldable		32	279	587		HD Plate Right	33
			<b>1J-1300</b>		Soldable		32	279	587		HD Plate Left	33
<b>80</b>	Straight Moldboard (old type)	5W	<b>5J-6859</b>		1x3	19	25	330	2.883		Center Blade	176
			<b>4T-6617</b>	7J-3678	1x3	9	25	330	1.378		Center Blade	84
			<b>4T-6565</b>	5J-6817	1x3	9	25	406	1.378		Center Blade	103
<b>DW21</b>	Straight Moldboard (old type)	8J	<b>4T-2900</b>	5J-6828	1x3	9	32	406	1.378		Center Blade	130
			<b>CA1-ST0759</b>		1x3 1/2	9	64	483	1.378		Serrated Blade	220
<b>DW20</b>	Straight Moldboard (old type)	11C	<b>4T-6612</b>	7J-3193	1x3	5	25	330	749		Lateral Blade	46
			<b>4T-6380</b>	5J-6863	1x3	5	32	330	749		Lateral Blade	58
			<b>8F-7232</b>	4F-7838	3/4x2 1/2	5	19	203	406		End Bit	12
			<b>6F-3319</b>		Soldable		32	222	578		HD Plate Right	25
<b>6F-3320</b>		Soldable		32	222	578		HD Plate Left	25			
<b>90</b>		9V	<b>5J-6869</b>		1x3	20	25	330	3.035		Center Blade	186
			<b>4T-6620</b>	7J-3558	1x3	10	25	330	1.530		Center Blade	93
			<b>4T-2887</b>	5J-6818	1x3	10	25	406	1.530		Center Blade	114
			<b>4T-2895</b>	5J-6827	1x3	10	32	406	1.530		Center Blade	144
			<b>4T-6612</b>	7J-3193	1x3	5	25	330	749		Lateral Blade	46
			<b>4T-6380</b>	5J-6881	1x3	5	32	330	749		Lateral Blade	58
			<b>5F-6532</b>		3/4x2 1/2	6	19	229	508		End Bit	19
<b>428</b>		43D, 44D	<b>4T-6621</b>	7J-3564	1x3	8	25	330	1.226		Center Blade	75
<b>435</b>		45D1-UP 35E, 85F 88F	<b>4T-6567</b>	5J-6819	1x3	8	25	406	1.226		Center Blade	91
			<b>4T-2891</b>	5J-6822	1x3	8	32	406	1.226		Center Blade	117
			<b>CA1-ST0773</b>		1x3 1/2	8	64	457	1.226		Serrated Blade	179
<b>442</b>		83E, 33F	<b>4T-6612</b>	7J-3193	1x3	5	25	330	749		Lateral Blade	46
<b>619</b>		68F	<b>4T-6380</b>	5J-6863	1x3	5	32	330	749		Lateral Blade	58
<b>619-C</b>		45F, 48F 68F1-UP	<b>4T-2894</b>	7J-4805	1x3	5	32	406	749		Lateral Blade	72
			<b>1J-1724</b>		3/4x2 1/2	5	25	254	406		End Bit	20
			<b>1J-1299</b>		Soldable		32	279	587		HD Plate Right ø 3/4"	33
			<b>1J-1300</b>		Soldable		32	279	587		HD Plate Left ø 3/4"	33
			<b>2J-9193</b>		Soldable		32	318	612		HD Plate Right ø 1"	41
<b>2J-9194</b>		Soldable		32	318	612		HD Plate Left ø 1"	41			
<b>456</b>		60C, 61C	<b>5J-6869</b>		1x3	20	25	330	3.035		Center Blade	186
<b>463</b>		62C, 62F	<b>4T-6620</b>	7J-3558	1x3	10	25	330	1.530		Center Blade	93
<b>470</b>		86F, 93D	<b>4T-2887</b>	5J-6818	1x3	10	25	406	1.530		Center Blade	114
		94D	<b>4T-2895</b>	5J-6820	1x3	10	32	406	1.530		Center Blade	144
			<b>CA1-ST0760</b>		1x3 1/2	10	64	483	1.530		Serrated Blade	261

	Type	Serie	Ref.		Inches 	n°	mm.				Description	
			Present	Old								
			<b>4T-6612</b>	7J-3193	1x3	5	25	330	749		Lateral Blade	46
			<b>4T-6380</b>	5J-6863	1x3	5	32	330	749		Lateral Blade	58
			<b>1J-1724</b>		3/4x2 3/4	5	25	254	406		End Bit	20
			<b>1J-1299</b>		Soldable		32	279	587		HD Plate Right ø 3/4 "	33
			<b>1J-1300</b>		Soldable		32	279	587		HD Plate Left ø 3/4 "	33
			<b>2J-9193</b>		Soldable		32	318	610		HD Plate Right ø 1 "	41
			<b>2J-9194</b>		Soldable		32	318	610		HD Plate Left ø 1 "	41
<b>482</b>		72E	<b>5J-6875</b>	2J-6581	1x3	11	32	330	1.683		Center Blade	131
			<b>5J-6821</b>	2J-6593	1x3	11	32	406	1.683		Center Blade	159
			<b>4T-6380</b>	5J-6881	1x3	5	32	330	749		Lateral Blade	58
<b>491</b>		98C	<b>5J-6869</b>		1x3	20	25	330	3.035		Center Blade	186
			<b>4T-6620</b>	7J-3558	1x3	10	31	25	102		Center Blade	93
			<b>4T-2887</b>	5J-6818	1x3	10	25	406	1.530		Center Blade	114
			<b>4T-2895</b>	5J-6827	1x3	10	32	406	1.530		Center Blade	144
			<b>CA1-ST0760</b>		1x3 1/2	10	64	483	1.530		Serrated Blade	261
			<b>4T-6612</b>	7J-3193	1x3	5	25	330	749		Lateral Blade	46
			<b>4T-6380</b>	5J-6863	1x3	5	32	330	749		Lateral Blade	58
			<b>1J-4348</b>		3/4x3	6	32	229	508		End Bit	29
<b>621</b>		37G	<b>CA1-SC0356</b>		1x2 3/4	9	25	330	1.429		Center Blade	86
<b>627</b>		50K1-UP 69M, 37V 38V	<b>4T-6568</b>	5J-6845	1x2 3/4	9	25	406	1.429		Center Blade	108
			<b>4T-5896</b>	6J-440	1x3	9	32	406	1.429		Center Blade	137
			<b>4T-2896HD</b>	6J-440HD	1x3	9	38	406	1.429		Center Blade	166
<b>621B</b>		36V	<b>CA1-ST0652</b>		1x3 1/2	9	64	483	1.427		Serrated Blade	245
<b>627B</b>		37V, 38V	<b>4T-6612</b>	7J-3193	1x2 3/4	5	25	330	749		Lateral Blade	46
<b>621E</b>		6AB	<b>4T-6380</b>	5J-6881	1x3	5	32	330	749		Lateral Blade	58
<b>627E</b>		6FB, 6HB	<b>4T-6380HD</b>	5J-6881HD	1x3	5	38	330	749		Lateral Blade	72
			<b>4T-2894</b>	7J-4805	1x3	5	32	406	749		Lateral Blade	72
			<b>5J-2171</b>		Soldable		32	394	629		HD Plate Right	42
			<b>5J-2172</b>		Soldable		32	394	629		HD Plate Left	42
<b>613</b>	Elevating	72M	<b>4T-6611</b>	7J-4690	3/4x2 1/2	7	25	330	1.102		Center Blade	66
<b>613B</b>	Scraper		<b>4T-6611HD</b>	7J-4690HD	2/4x2 1/2	7	32	330	1.102		Center Blade	83
<b>613C</b>	Elevating	93X1-UP	<b>CA1-ST0588</b>		3/4x3	14	44	483	1.102		Serrated Blade	129
	Scraper		<b>4T-6613</b>	7J-4689	2/4x2 1/2	4	25	330	562		Lateral Blade	34
			<b>4T-6613HD</b>	7J-4689HD	2/4x2 1/2	4	32	330	562		Lateral Blade	43
			<b>9F-1831</b>	4F-4357	5/8x2 1/2	4	16	203	356		End Bit (S/N 72M)	9
			<b>4T-4336</b>		5/8x2 1/2	3	19	200	448		End Bit (S/N 93X)	10
<b>615</b>	Elevating	47Z1-1339	<b>7T-5104</b>	3G-4053	7/8x3	9	25	330	1.486		Center Blade	88
	Scraper		<b>7T-5105</b>	3G-4054	7/8x3	4	25	330	560		Lateral Blade	33
			<b>CA2-ST0618</b>		7/8x3	9	51	508	1.486		Serrated Blade	191
<b>615C</b>	Elevating	47Z1340-UP	<b>9W-5807</b>		1x3 1/4	9	25	406	1.508		Center Blade	111
	Scraper		<b>9W-5810</b>		1x3 1/4	4	25	330	538		Lateral Blade	32
			<b>9W-5806</b>		1x3 1/4	4	25	406	538		Lateral Blade	39
<b>619</b>	Elevating	43F-1-UP	<b>4T-6620</b>	7J-3558	1x3	10	25	330	1.530		Center Blade	93
	Scraper		<b>4T-2887</b>	5J-6818	1x3	10	25	406	1.530		Center Blade	114
<b>621</b>	Elevating	43H1-UP	<b>4T-2895</b>	5J-6827	1x3	10	32	406	1.530		Center Blade	144
	Scraper		<b>CA1-ST0479</b>		1x3 1/2	10	51	508	1.530		Serrated Blade	200
<b>623</b>	Elevating	26U	<b>4T-6612</b>	7J-3193	1x3	5	25	330	749		Lateral Blade	46
	Scraper		<b>4T-6380</b>	7J-6863	1x3	5	32	330	749		Lateral Blade	58
<b>623B</b>	Elevating	61E										
	Scraper											



	Type	Serie	Ref.		Inches 	n°	mm.				Description		
			Present	Old									
<b>623E</b>	Elevating Scraper	6DB											
<b>630A</b>		60F	<b>5J-6869</b>		1x2 3/4	20	25	330	3.035		Center Blade	186	
<b>631A</b>		56F	<b>4T-6620</b>	7J-3558	1x2 3/4	10	25	330	1.530		Center Blade	93	
				<b>4T-2887</b>	5J-6818	1x2 3/4	10	25	406	1.530		Center Blade	114
				<b>4T-2895</b>	5J-6827	1x3	10	32	406	1.530		Center Blade	144
				<b>4T-6372</b>	8J-7160	1x3	10	38	406	1.530		Center Blade	175
				<b>7J-2958</b>		1x3	10	44	406	1.530		Center Blade	195
				<b>CA1-ST0760</b>		1x3 1/2	10	64	483	1.530		Serrated Blade	261
				<b>4T-6612</b>	7J-3193	1x2 3/4	5	25	330	749		Lateral Blade	46
				<b>4T-6380</b>	5J-6863	1x3	5	32	330	749		Lateral Blade	58
				<b>4T-6380HD</b>	5J-6863HD	1x3	5	38	330	749		Lateral Blade	72
				<b>4T-6380XHD</b>	5J-6881XHD	1x3	5	44	330	749		Lateral Blade	79
				<b>2J-9193</b>		Soldable		32	318	610		HD Plate Right ø 1 "	41
				<b>2J-9194</b>		Soldable		32	318	610		HD Plate Left ø 1 "	41
<b>491</b>			47E	<b>4T-6617</b>	7J-3678	1x3	9	25	330	1.378		Center Blade	84
<b>630,630B</b>		10G1-UP	<b>4T-6565</b>	5J-6817	1x3	9	25	406	1.378		Center Blade	103	
<b>630BSA</b>		SA32F1-UP	<b>4T-2900</b> <b>4T-6314</b>	5J-6828 8J-7192	1x3	9	32	406	1.378		Center Blade	130	
<b>631,631B</b>		11G1-UP	<b>4T-6375</b>	7J-3026	1x3	9	38	406	1.378		Center Blade	154	
<b>631C</b>			<b>7J-2957</b>		1x3	9	44	406	1.378		Center Blade	175	
<b>631BSA</b>		SA28F1-UP	<b>CA1-ST0759</b>		1x3 1/2	9	64	483	1.378		Serrated Blade	220	
<b>637</b>		64M, 91N	<b>4T-6614</b>	7J-3025	1x3	6	25	330	902		Lateral Blade	54	
			<b>4T-6378</b> <b>4T-2305</b>	6J-5945 8J-7187	1x3	6	32	330	902		Lateral Blade	70	
			<b>4T-2332</b>	8J-7141	1x3	6	38	330	902		Lateral Blade	86	
			<b>7J-2959</b>		1x3	6	44	330	902		Lateral Blade	95	
			<b>4T-6308</b>	8J-7744	1x3	6	32	406	902		Lateral Blade	84	
			<b>4T-6374</b>	8J-7158	1x3	6	38	406	902		Lateral Blade	103	
			<b>4J-9112</b>		1x3	10	32	356	1.519		Grader Blade L	126	
			<b>4J-9113</b>		1x3	11	32	356	1.670		Cuchilla nivel. der.	139	
			<b>5J-3101</b>		Soldable		32	391	702		HD Plate Right	54	
			<b>5J-3102</b>		Soldable		32	391	702		HD Plate Left	54	
			<b>3J-6939</b>		Soldable		32	400	722		HD Plate Right	55	
			<b>3J-6940</b>		Soldable		32	400	722		HD Plate Left	55	
			<b>4J-6773</b>		Soldable		32	445	762		HD Plate Right	64	
			<b>4J-6774</b>		Soldable		32	445	762		HD Plate Left	64	
			<b>7J-4227</b>		Soldable		32	391	702		HD Plate Right	54	
			<b>7J-4228</b>		Soldable		32	391	702		HD Plate Left	54	
<b>631D</b>		28W1-UP	<b>4T-6566</b>	9J-565	1x3	10	25	406	1.572		Center Blade	117	
<b>631SA</b>		29W	<b>4T-3444</b> <b>4T-6310</b>	9J-5901 1U-0695	1x3	10	32	406	1.572		Center Blade	149	
<b>637D</b>			<b>4T-6371</b>	9J-4369	1x3	10	38	406	1.572		Center Blade	180	
<b>637SA</b>		20W, 21W 22W, 23W	<b>9J-5899</b>		1x3	10	44	406	1.572		Center Blade	212	
			<b>CA1-ST0977</b>		1x3 1/2	10	64	483	1.572		Serrated Blade	251	
<b>637D</b>	Auger		<b>4T-6614</b>	7J-3025	1x3	6	25	330	902		Lateral Blade	54	
<b>631E</b>		1BB	<b>4T-6378</b> <b>4T-2305</b>	6J-5945 8J-7187	1x3	6	32	330	902		Lateral Blade	70	
<b>637E</b>		1HB, 1LB 7CB	<b>4T-2332</b>	8J-7141	1x3 1/2	6	38	330	902		Lateral Blade	86	
			<b>7J-2959</b>		1x3 1/2	6	44	330	902		Lateral Blade	95	
			<b>7J-3023</b>		1x3 1/2	5	32	254	584		End Bit	40	
<b>641</b>		80F, 42M	<b>4T-6620</b>	7J-3558	1x3 1/2	10	25	330	1.530		Center Blade	93	

	Type	Serie	Ref.		Inches 	n°	mm.				Description	
			Present	Old			mm.	mm.	mm.			
<b>632</b>		43M	<b>4T-2887</b>	5J-6820	1x3 1/2	10	25	406	1.530		Center Blade	114
<b>632</b>		79F	<b>4T-2895</b> <b>4T-6309</b>	5J-6827 8J-7189	1x3 1/2	10	32	406	1.530		Center Blade	144
<b>641SA</b>		70G	<b>4T-6372</b>	8J-7160	1x3 1/2	10	38	406	1.530		Center Blade	175
<b>632SA</b>		71G	<b>7J-2958</b>		1x3 1/2	10	44	406	1.530		Center Blade	195
<b>641B</b>		42M, 43M 70G	<b>CA1-ST0760</b>		1x3 1/2	10	64	483	1.530		Serrated Blade	261
			<b>4T-6614</b>	7J-3025	1x3 1/2	6	25	330	902		Lateral Blade	54
			<b>4T-6378</b> <b>4T-2305</b>	5J-5945 8J-7187	1x3 1/2	6	32	330	902		Lateral Blade	70
			<b>4T-2332</b>	8J-7141	1x3 1/2	6	38	330	902		Lateral Blade	86
			<b>7J-2959</b>		1x3 1/2	6	44	330	902		Lateral Blade	95
			<b>4T-6308</b>	8J-7744	1x3	6	32	406	902		Lateral Blade	84
			<b>4T-6374</b>	8J-7158	1x3 1/2	6	38	406	902		Lateral Blade	103
			<b>4J-9113</b>		1x3 1/2	11	32	356	1.670		2 Pc Level Cut	139
			<b>3J-6939</b>		Soldable		32	400	722		HD Plate Right	55
			<b>3J-6940</b>		Soldable		32	400	722		HD Plate Left	55
			<b>7J-3023</b>		1x3 1/2	5	32	254	584		End Bit	40
<b>633</b>	Elevating Scraper	86H	<b>4T-6316</b> <b>4T-2892</b>	8J-7188 5J-6826	1x3 1/2	11	32	406	1.734		Center Blade	164
<b>633B</b>	Elevating Scraper		<b>4T-6373</b>	8J-7161	1x3 1/2	11	38	406	1.734		Center Blade	197
<b>633C</b>	Elevating Scraper		<b>5J-860</b>		1x3 1/2	22	32	483	1.734		Center Blade	203
			<b>5J-8060HD</b>		1x3 1/2	22	38	483	1.734		Center Blade	234
			<b>CA1-ST0643</b>		1x4	22	57	584	1.732		Serrated Blade	285
			<b>4T-3429</b> <b>4T-6313</b>	7J-3022 8J-7193	1x3 1/2	5	32	406	724		Lateral Blade	69
			<b>7J-3192</b>		1x3 1/2	5	38	406	724		Lateral Blade	84
			<b>5J-8062</b>		1x3 1/2	5	25	330	724		Lateral Blade	43
			<b>5J-8062HD</b>		1x3 1/2	5	32	330	724		Lateral Blade	56
			<b>5J-8062XHD</b>		1x3 1/2	5	38	330	724		Lateral Blade	68
			<b>5J-8643</b>		5/8x2 1/2	10	19	152	1.562		Strike Off, 2 Reqd	36
<b>633D</b>	Elevating Scraper	19W1-UP	<b>4T-3428</b> <b>4T-6319</b>	9J-1110 1U-696	1x3 1/2	11	32	406	1.661		Center Blade	160
			<b>9J-1111</b>		1x3 1/2	11	38	406	1.661		Center Blade	193
<b>639D</b>	Elevating Scraper	88X1-UP	<b>CA1-ST0978</b>		1x3 1/2	11	57	584	1.661		Serrated Blade	273
			<b>4T-2899</b> <b>4T-6318</b>	9J-1112 1U-0697	1x3 1/2	6	32	406	857		Lateral Blade	83
			<b>9J-1109</b>		1x3 1/2	6	38	406	857		Lateral Blade	100
<b>651E</b>		88Z1-145	<b>9W-4505</b>	4T-8795	1 1/4x4	13	32	406	1.734		Center Blade	157
<b>657E</b>		86Z1-240 6MB1-90	<b>9W-4394</b> <b>9W-4399</b> <b>9W-4509</b> <b>4T-668</b>	4T-8802 4T-3892 4T-3894	1 1/4x4 1 1/4x4 1 1/4x4 1 1/4x4	13 8 8 5	38 32 38 38	406 330 330 254	1.734 965 965 584		Center Blade Lateral Blade Lateral Blade End Bit	186 72 87 49
<b>651E</b>		88Z146-UP	<b>9W-4901</b>		1x3 1/4	24	38	483	1.822		Center Blade	235
<b>657E</b>		86Z241-UP 6M-B91-UP	<b>9W-9701</b> <b>9W-4902</b> <b>9W-9702</b>		1x3 1/4 1x3 1/4 1x3 1/4	24 12 12	44 38 44	483 406 406	1.822 904 908		Center Blade Lateral Blade Lateral Blade	275 102 117
<b>650</b>		22G1-164	<b>4T-6316</b> <b>4T-2892</b>	8J-7188 5J-6826	1x3 1/2	11	32	406	1.734		Center Blade	164
<b>651</b>		23G1-126	<b>4T-6373</b>	8J-7161	1x3 1/2	11	38	406	1.734		Center Blade	197
<b>657</b>		19G1-221	<b>7J-2981</b>		1x3 1/2	11	44	406	1.734		Center Blade	229
<b>660</b>		18G1-77	<b>CA1-ST0957</b>		1x4	11	64	610	1.732		Serrated Blade	394
<b>666</b>		20G1-93	<b>4T-2305</b> <b>4T-6378</b>	8J-7187 6J-5945	1x3 1/2	6	32	330	902		Lateral Blade	70
<b>660B</b>		18G	<b>4T-2332</b>	8J-7141	1x3 1/2	6	38	330	902		Lateral Blade	86

	Type	Serie	Ref.		Inches 	n°	mm.				Description	
			Present	Old								
			<b>7J-2959</b>		1x3 1/2	6	44	330	902		Lateral Blade	95
			<b>4T-6374</b>	8J-7158	1x3 1/2	6	38	406	902		Lateral Blade	103
			<b>7J-2978</b>		1x3 1/2	6	44	406	902		Lateral Blade	120
			<b>4J-9209</b>		1x3 1/2	11	38	356	1.695		Grader Blade R	163
			<b>4J-9210</b>		1x3 1/2	12	38	356	1.854		Grader Blade L	179
			<b>7J-3023</b>		1x3 1/2	5	32	254	584		End Bit	40
			<b>3J-6939</b>		Soldable		32	400	722		HD Plate Right	55
			<b>3J-6940</b>		Soldable		32	400	722		HD Plate Left	55
<b>650</b>		22G165-UP	<b>4T-6315</b>	8J-7191	1x3 1/2	11	32	406	1.734		Center Blade	163
<b>650B</b>		22G	<b>4T-6373</b>	8J-7161	1x3 1/2	11	38	406	1.734		Center Blade	202
<b>651</b>		23G127-UP	<b>7J-2981</b>		1x3 1/2	11	44	406	1.734		Center Blade	229
<b>651B</b>		45MI-UP	<b>4T-6556</b>	8J-7745	1x3 1/2	22	32	483	1.734		Center Blade	184
<b>657</b>		19G222-UP	<b>4T-6555</b>	8J-7568	1x3 1/2	22	38	483	1.734		Center Blade	234
<b>657-B</b>		47M1-UP	<b>7J-2977</b>		1x3 1/2	22	44	483	1.734		Center Blade	272
		53K	<b>CA1-ST0796</b>		1x4	22	64	584	1.732		Serrated Blade	372
<b>660</b>		18G78-UP	<b>4T-6308</b>	8J-7744	1x3 1/2	12	32	406	902		Lateral Blade	84
<b>660-B</b>		20G94-UP	<b>4T-6374</b>	8J-7158	1x3 1/2	12	38	406	902		Lateral Blade	103
<b>666</b>			<b>7J-2978</b>		1x3 1/2	12	44	406	902		Lateral Blade	120
			<b>7J-3023</b>		1x3 1/2	5	32	254	584		End Bit	40

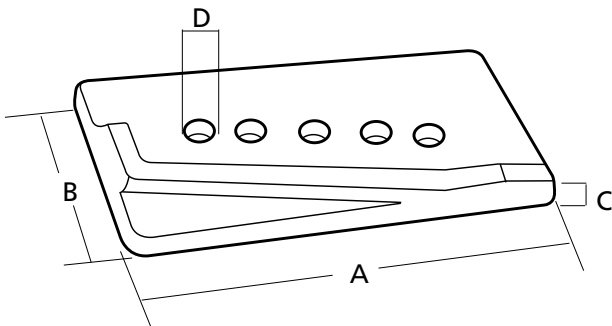
## Rovier Bit for Cat Scraper



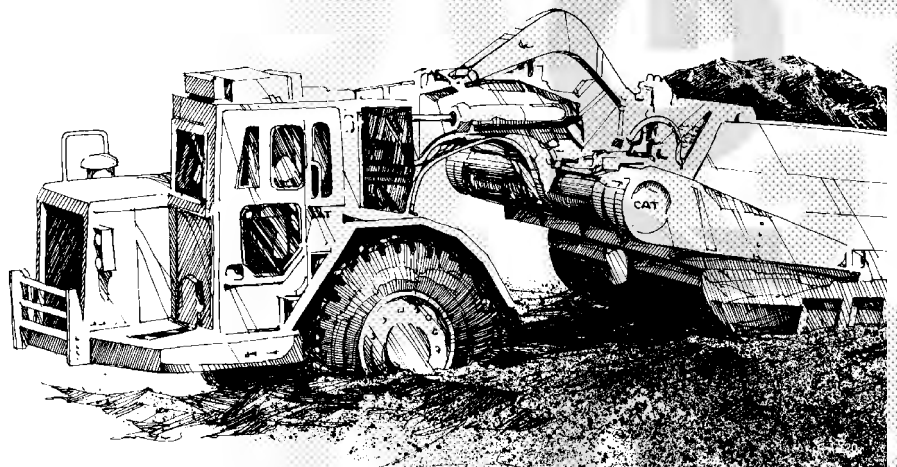

	mm.				n°	
	A	B	C	D		
9F-1831	355	203	16	5/8"	4	PB-505
8F-7232	406	203	19	3/4"	5	PB-322
<b>4J-8665</b>	510	220	25	1"	5	PB-942
4T-0698	555	240	35	1"	5	PB-942
<b>7J-3023</b>	584	254	38	1"	5	PB-542



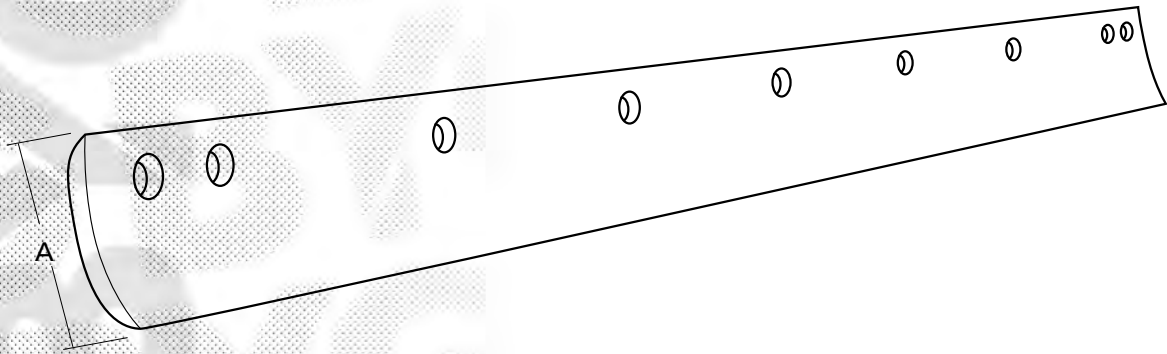

## Curved Cutting Edges for Graders



**A= 6" (152mm)**

								Ø
	5' - 1524 mm.	5' - 1524 mm.	6' - 1828 mm.	6' - 1828 mm.	7' - 2133 mm.	7' - 2133 mm.	8' - 2438 mm.	
5/8"	<b>5B-5567</b>	<b>7D-4508</b>	<b>*5B-5564-450</b>	<b>*5D-9553-450</b>	<b>*5B-5561-450</b>	<b>*5D-9554-450</b>	<b>8J-4043</b>	5/8"
16 mm				<b>9J-3657</b>		<b>9J-3658</b>	<b>9J-3655</b>	3/4"
3/4"		<b>3G-7966</b>		<b>*5D-9556-450</b>		<b>5D-9557</b>		5/8"
19 mm								3/4"
	7	11	8	13	9	15	17	



**A= 8" (203mm)**

							Ø
	2' - 610 mm	4' - 1219 mm.	5' - 1524 mm.	6' - 1828 mm.	7' - 2133 mm.	8' - 2438 mm.	
5/8"			<b>7D-4509</b>	<b>5D-9562</b>	<b>5D-9561</b>	<b>5D-9731</b>	5/8"
16 mm	<b>3G-2166</b>			<b>9J-7701</b>	<b>7D-1158</b>	<b>8J-9821</b>	3/4"
3/4"	<b>6G-8623</b>			<b>*5D-9558-450</b>	<b>*5D-9559-450</b>	<b>5D-9732</b>	5/8"
19 mm	<b>3G-2165</b>			<b>7D-1576</b>	<b>*7D-1577-450</b>	<b>7D-1949</b>	3/4"
1"			<b>4T-2240</b>	<b>4T-2244</b>	<b>4T-2242</b>	<b>4T-2237</b>	5/8"
25 mm				<b>4T-2231</b>	<b>*4T-2233-450</b>	<b>*4T-2236-450</b>	3/4"
	4	9	11	13	15	17	



\* Cutting edges de acero de 450 HB

## Straight Cutting Edges for Graders

**A= 8" (203mm)**

					Ø
	5' - 1524 mm.	6' - 1828 mm.	7' - 2133 mm.	8' - 2438 mm.	
5/8"	<b>4T-2967</b>	<b>4T-2968</b>	<b>4T-2969</b>	<b>4T-2966</b>	5/8"
16 mm		<b>4T-2971</b>	<b>4T-2970</b>	<b>4T-9603</b>	3/4"
3/4"	<b>4T-3034</b>	<b>4T-3007</b>	<b>4T-3036</b>	<b>4T-3035</b>	5/8"
19 mm		<b>4T-3033</b>	<b>4T-3032</b>	<b>4T-3037</b>	3/4"
1"	<b>7T-3497</b>	<b>7T-3499</b>	<b>7T-3498</b>	<b>7T-3496</b>	5/8"
25 mm		<b>7T-3493</b>	<b>7T-3494</b>	<b>7T-3495</b>	3/4"
	11	13	15	17	

**A= 10" (254mm)**

				Ø
	6' - 1828 mm.	7' - 2133 mm.	8' - 2438 mm.	
1"	<b>4T-6502</b>	<b>4T-6508</b>	<b>4T-6511</b>	3/4"
25 mm				
	13	15	17	

## Grader Moldboard

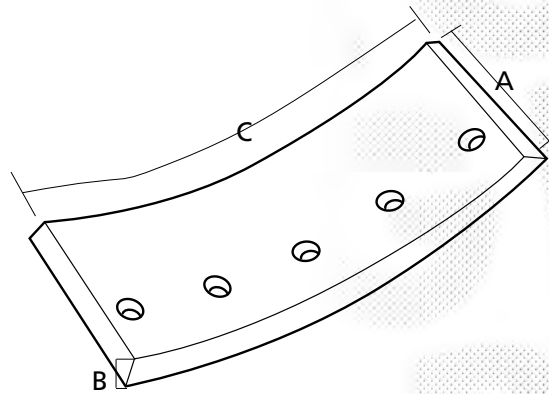

mm.			KG	N°	Part Number	Screw	Nut	N° Tal	Serie	Machine
A	B"	C								
152	19,5	480	10	2	<b>9D-4880/1</b>	4F-7827	2J-3506	4	93U1-2777	16G
160	19,5	480	8,8		<b>8E-5530</b>	5J-4773	2J-3506	5	93U2778-UP	16G/H
152	5/8	480	7,3		<b>4D-9811/2</b>	3F-5108	4K-0367	4	All the others	16
152	5/8	480	7,7	2	<b>9J-4405/6</b>	4F-7827	2J-3506	4	96U1-7324	14G
152	5/8	475	7,8		<b>8E-5529</b>	5J-4773	2J-3506	5	96U7325-UP	14G/H
152	1/2	553	6,5		<b>7D-2083/4</b>	3F-5108	4K-0367	5	All the others	14
152	1/2	475	6,5	2	<b>7D-2052</b> <b>9W-2945</b>	3F-5108	4K-0367	5	All	112,12, 120,130, 140
152	5/8	475	7,8	2	<b>8E-5531</b>	3F-5108	4K-0367	5	61M11716 87V06135 74V02293 72V09829	12G/H 120G/H 130G 40G
			4,5	2	9J-4411	3F-5108	4K-0367	4	All	212
152	5/8	475	7,8	2	<b>8E-5529</b>	5J-4773	2J-3506	5	All	160H
152	5/8	475	7,9	2	<b>8E-5531</b>	3F-5108	4K-0367	5	All	135H

## Grader Overlay

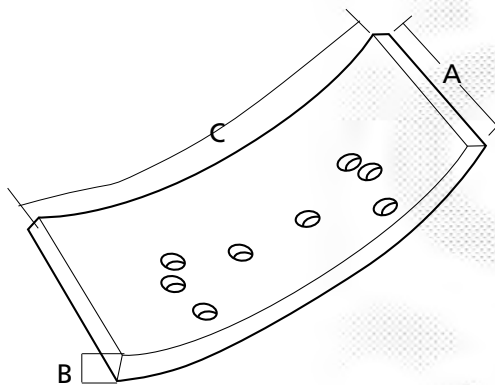

mm.			KG	Type	Part Number	Screw	Nut	N° tal	Cutting Edge	Pulg	mm	Machine	
A	B"	C											
235	5/8	565	11,5	Rev-1	<b>6D-1948 HD</b>	4F-3658	4K-0367		Curved	203		12,120,130,140 1°Series 14 1°Series 16 14G, 16G	
235	1/2	565	10,5		<b>6D-1948</b>	4F-3658	4K-0367						
235	1/2	585	12		<b>7D-5583</b>	1J-6762	2J-3506						
235	1/2	605	12,5		<b>7D-1596</b>	4F-3658	4K-0367						
235	5/8	600	12,5		<b>7D-9999 HD</b>	1J-6762	2J-3506						
235	1/2	600	11,5		<b>7D-9999</b>	1J-6762	2J-3506						
235	1/2	565	11,5	Rev-1	<b>6Y-2805</b>	1J-6762	2J-3506					14H,16H,14G 96U7325-UP 160H,16G 93U2778-UP	
235	1/2	565	11,6	Rev-1	<b>9W-1768</b>	4F-3658	4K-0367					12H,12G (61M11716 y sig), 120H,120G, (87V06135 y sig), 135H,130G,(74V02293 & ...), 140H,140G, (72V09829 &...)	
235	1/2	460	9,4		<b>9W-1767</b>	4F-3658	4K-0367						
235	5/8	475	10,5	Rev-1	<b>6D-1904 HD</b>	4F-3658	4K-0367				6"	152	6, 152, 12,120,130,140, 1°Series 14-16
235	1/2	475	9,5		<b>6D-1904</b>	4F-3658	4K-0367						
235	1/2	478	9	Rev-1	7D-5582	1J-6762	2J-3506				8"	203	1°Series 16
230	5/8	490	9,5	No Rev-1	<b>4D-5757/8</b>	4F-3658	4K-0367		Straight8"	203			12,120,130,140, Ult. Series 14

# Loader Blades

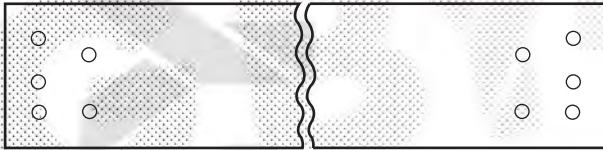

Fig 1

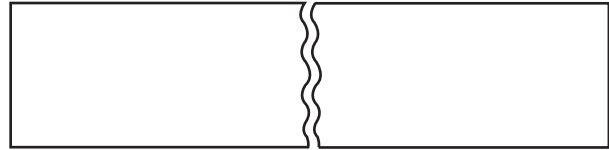

Fig 3



Fig 2

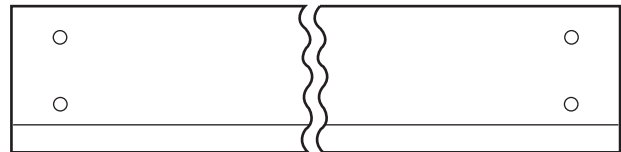
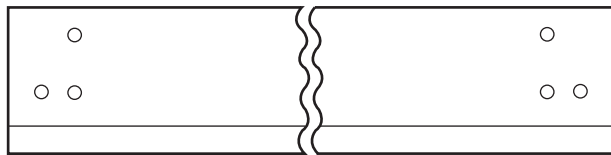

Fig 4

Ref.				Nº		Type
<b>5G-2808</b>	19	191	1823	14		<b>5</b>
<b>6S-6501</b>	19	191	1898	12		<b>1</b>
<b>5G-8467</b>	19	191	1950	14		<b>5</b>
<b>5V-7419</b>	25	245	2006	10		<b>4</b>
<b>6W-2977</b>	25	245	2018	28	6	<b>2</b>
<b>9K-8471</b>	25	228	2076			<b>3</b>
<b>4V-8335</b>	25	245	2078	16		<b>1</b>
<b>9V-6571</b>	25	245	2078	28	6	<b>2</b>
<b>5G-2809</b>	19	191	2080	12		<b>5</b>
<b>5G-3085</b>	19	191	2150	12		<b>5</b>
<b>5G-6133</b>	20	191	2150	24	6	<b>2</b>
<b>9V-6570</b>	25	245	2202	28	6	<b>2</b>
<b>4V-8850</b>	25	245	2202	16		<b>1</b>
<b>6W-2978</b>	32	282	2237	30	6	<b>2</b>
<b>6W-2978</b>	30	300	2237	30	6	<b>2</b>
<b>6W-2978</b>	32	282	2237	30	6	<b>2</b>
<b>6W-2976</b>	25	245	2248	28	6	<b>2</b>
<b>8V-7453</b>	25	245	2248	16		<b>1</b>
<b>5V-7437</b>	25	245	2248	16		<b>4</b>
<b>9R-4672</b>	20	150	2262	16	8	<b>7</b>
<b>6W-2979</b>	32	282	2268	30	6	<b>2</b>
<b>4V-4958</b>	30	282	2268	18		<b>1</b>
<b>1V-9077</b>	25	228	2286			<b>3</b>
<b>5V-7426</b>	25	245	2314	16		<b>4</b>
<b>6W-2975</b>	25	245	2324	28	6	<b>2</b>
<b>5G-3477</b>	19	191	2330	12		<b>5</b>

Ref.				Nº		Type
<b>9V-6572</b>	25	245	2370	16	6	<b>2</b>
<b>5V-4670</b>	25	245	2370	16		<b>1</b>
<b>9R-5313</b>	20	150	2396	16	8	<b>4</b>
<b>6S-7291</b>	20	191	2406	14	7	<b>4</b>
<b>6W-2984</b>	25	245	2408	28	8	<b>2</b>
<b>6W-2986</b>	25	245	2411	30		<b>7</b>
<b>6W-2983</b>	40	300	2430	30	6	<b>2</b>
<b>5V-7263</b>	32	282	2432	18		<b>1</b>
<b>7V-0782</b>	32	266	2438			<b>3</b>
<b>5V-7423</b>	25	245	2439	18		<b>4</b>
<b>4V-3174</b>	30	282	2474	18		<b>1</b>
<b>6W-2980</b>	30	282	2474	30	6	<b>2</b>
<b>9K-8472</b>	32	266	2489			<b>3</b>
<b>8A-8443</b>	25	245	2574	16		<b>1</b>
<b>6W-2982</b>	40	300	2602	30	6	<b>2</b>
<b>5V-0600</b>	40	300	2602	18		<b>1</b>
<b>6W-2987</b>	25	245	2615	30	6	<b>2</b>
<b>6W-2985</b>	25	245	2639	28	6	<b>2</b>
<b>8V-1825</b>	25	245	2639	16		<b>1</b>
<b>5V-7422</b>	25	245	2642	16		<b>4</b>
<b>1V-3915</b>	25	228	2686			<b>3</b>
<b>5G-7303</b>	40	300	2702	18		<b>1</b>
<b>6W-2994</b>	45	470	2705	12		<b>7</b>
<b>9V-0255</b>	51	330	2714			<b>3</b>
<b>9V-6573</b>	32	282	2736	30	6	<b>2</b>
<b>5V-7421</b>	25	245	2743	16		<b>4</b>

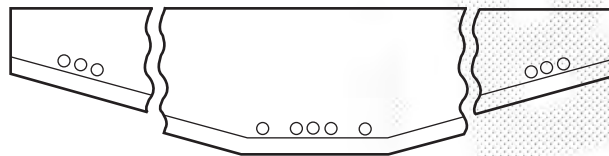



**Fig 5**



**Fig 6**





**Fig 7**

Ref.				N°		Type
<b>5V-7410</b>	25	245	2744	12		<b>1</b>
<b>5V-4696</b>	30	282	2800	18		<b>1</b>
<b>7V-0898</b>	40	300	2805	18		<b>1</b>
<b>6W-2973</b>	35	493	2815	18		<b>7</b>
<b>9C-0967</b>	35	493	2815			<b>7</b>
<b>6W-2989</b>	32	282	2840	30	6	<b>2</b>
<b>6W-2981</b>	40	300	2846	30	6	<b>2</b>
<b>4V-9714</b>	40	300	2846	18		<b>1</b>
<b>6W-2990</b>	32	282	2856	30	6	<b>2</b>
<b>5V-7418</b>	25	245	2890			<b>3</b>
<b>7V-6844</b>	40	300	2912	18		<b>1</b>
<b>1V-3917</b>	32	266	2921			<b>3</b>
<b>8K-9915</b>	32	266	2997			<b>3</b>
<b>7V-1490</b>	40	300	3032	18		<b>1</b>
<b>9V-6575</b>	40	300	3032	30	6	<b>2</b>
<b>9V-1306</b>	64	540	3035			<b>3</b>
<b>7V-0912</b>	30	282	3040	12		<b>1</b>
<b>8K-5000</b>	45	304	3067			<b>3</b>
<b>6W-2993</b>	45	580	3085	20		<b>7</b>
<b>9V-0170</b>	40	580	3085			<b>7</b>
<b>9V-0237</b>	50	330	3100			<b>3</b>
<b>6W-2991</b>	45	305	3179	30	6	<b>2</b>
<b>7K-2326</b>	45	304	3200			<b>3</b>
<b>5V-7415</b>	25	245	3226			<b>3</b>
<b>8V-5031</b>	32	282	3251	18		<b>4</b>
<b>8K-5056</b>	45	304	3270			<b>3</b>

Ref.				N°		Type
<b>2V-6118</b>	45	304	3286			<b>3</b>
<b>9V-0235</b>	50	330	3289			<b>3</b>
<b>5V-7420</b>	25	245	3302	18		<b>4</b>
<b>7V-4188</b>	45	305	3315	18		<b>1</b>
<b>9V-6574</b>	45	305	3315	30	6	<b>2</b>
<b>7V-0909</b>	40	300	3323	12		<b>1</b>
<b>8V-9581</b>	45	650	3370			<b>7</b>
<b>9V-3561</b>	45	647	3370	18		<b>7</b>
<b>8V-5032</b>	32	282	3404	20		<b>4</b>
<b>8V-9583</b>	60	700	3413			<b>7</b>
<b>6W-9311</b>	45	305	3560	18		<b>1</b>
<b>3V-0187</b>	45	304	3644	18		<b>6</b>
<b>8V-9585</b>	50	712	3644			<b>7</b>
<b>9C-2932</b>	50	330	3644	21	6	<b>2</b>
<b>9V-0232</b>	51	330	3644			<b>3</b>
<b>9V-3562</b>	50	706	3644	25		<b>7</b>
<b>7V-0779</b>	32	282	3810			<b>3</b>
<b>8K-9048</b>	57	830	4039			<b>7</b>
<b>9V-0008</b>	60	838	4312			<b>7</b>
<b>9V-0009</b>	57	445	4313			<b>3</b>
<b>3V-3890</b>	63,5	543	4597			<b>3</b>
<b>9V-0006</b>	63,5	838	4750			<b>7</b>
<b>9V-0007</b>	63,5	544	4750		8	<b>3</b>
<b>9V-3570</b>	63,5	921	4750			<b>7</b>
<b>9V-3566</b>	63,5	835	4750	28		<b>7</b>
<b>9V-0005</b>	63,5	921	4900			<b>7</b>
<b>9V-4370</b>	60	928	4900			<b>7</b>

## Bolt-On Segments for Cutting Edges

Ref.				Fig.
<b>4T-6691</b>	25	280	175	<b>2</b>
<b>4T-6692</b>	25	280	195	<b>2</b>
<b>4T-6693</b>	25	280	210	<b>2</b>
<b>4T-6694</b>	25	280	225	<b>2</b>
<b>4T-6695</b>	30	280	265	<b>2</b>
<b>4T-6696</b>	30	360	190	<b>2</b>
<b>4T-6697</b>	30	360	210	<b>2</b>
<b>4T-6698</b>	30	360	240	<b>2</b>
<b>4T-6699</b>	30	360	270	<b>2</b>
<b>4T-6700</b>	30	360	290	<b>2</b>
<b>4T-7139</b>	30	360	305	<b>1</b>
<b>4T-7140</b>	30	360	305	<b>1</b>
<b>4T-9123</b>	30	360	265	<b>1</b>
<b>4T-9124</b>	30	360	265	<b>1</b>
<b>4T-7183</b>	35	483	323	<b>1</b>
<b>4T-7184</b>	35	483	323	<b>1</b>
<b>4T-7189</b>	35	483	312	<b>2</b>
<b>9W-8367</b>	35	483	367	<b>1</b>
<b>9W-8368</b>	35	483	367	<b>1</b>
<b>4T-6760</b>	40	590	410	<b>2</b>
<b>4T-6761</b>	40	590	451	<b>1</b>

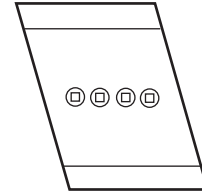

**Fig 1**

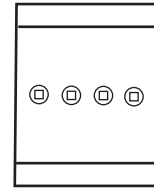
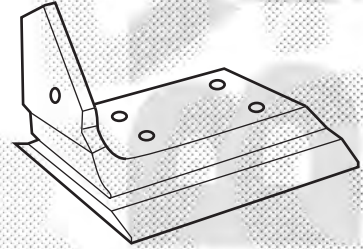

**Fig 2**

**Corner End Bits**

Ref.		$\emptyset$	Fig
<b>1U-0761</b>	40 556 265	1 1/4"	<b>1</b>
<b>1U-0764</b>	40 556 265	1 1/4"	<b>2</b>
<b>3G-6395</b>	35 510 200	1 1/4"	<b>1</b>
<b>1U-1897</b>	35 510 200	1 1/4"	<b>2</b>
<b>4T-8101</b>	30 496 170	1"	<b>1</b>
<b>1U-1898</b>	30 496 170	1"	<b>2</b>
<b>4T-8091</b>	25 342 160	1"	<b>3</b>
<b>1U-1896</b>	30 242 160	1"	<b>4</b>

**Fig 1**



**Fig 2**

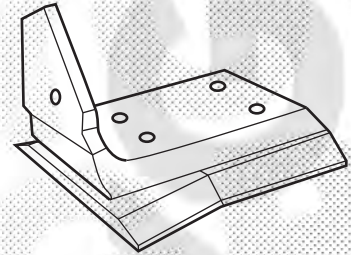

## Sub-Loader Blades

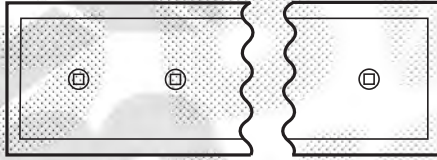

Fig 1

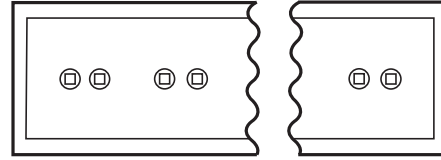





Fig 2

Ref.				Ø	Nº	Type
<b>4T-8069</b>	16	203	302	5/8"	3	<b>1</b>
<b>4T-8071</b>	16	203	257	5/8"	3	<b>1</b>
<b>4T-8078</b>	16	203	408	5/8"	4	<b>1</b>
<b>4T-8082</b>	16	203	349	5/8"	3	<b>1</b>
<b>4T-8085</b>	16	203	383	5/8"	3	<b>1</b>
<b>4T-8353</b>	20	203	463	3/4"	3	<b>1</b>
<b>4T-8372</b>	20	203	405	3/4"	3	<b>1</b>
<b>1U-2357</b>	20	254	1.308	3/4"	3	<b>1</b>
<b>4T-2910</b>	20	254	354	3/4"	2	<b>1</b>
<b>4T-2911</b>	20	254	1.143	3/4"	4	<b>1</b>
<b>4T-2912</b>	20	254	955	3/4"	4	<b>1</b>
<b>4T-2913</b>	20	254	1.308	3/4"	3	<b>1</b>
<b>4T-2914</b>	20	254	433	3/4"	2	<b>1</b>
<b>4T-2915</b>	20	254	1.486	3/4"	3	<b>1</b>
<b>4T-2918</b>	20	254	585	3/4"	2	<b>1</b>
<b>4T-2919</b>	20	254	946	3/4"	3	<b>1</b>
<b>4T-8796</b>	20	254	1.238	3/4"	3	<b>1</b>
<b>9W-9944</b>	20	254	373	3/4"	2	<b>1</b>
<b>1U-0292</b>	25	280	1.162	1"	3	<b>1</b>
<b>1U-0293</b>	25	280	941	1"	3	<b>1</b>
<b>1U-0294</b>	25	280	878	1"	3	<b>1</b>
<b>1U-0295</b>	25	280	1.025	1"	3	<b>1</b>
<b>1U-0605</b>	25	280	851	1"	3	<b>1</b>
<b>1U-0607</b>	25	280	1.044	1"	3	<b>1</b>
<b>1U-1464</b>	25	280	819	1"	3	<b>1</b>
<b>1U-1465</b>	25	280	788	1"	3	<b>1</b>
<b>1U-1467</b>	25	280	1.035	1"	4	<b>1</b>
<b>4T-9563</b>	25	280	967	1"	3	<b>1</b>
<b>8A-8444</b>	25	280	1.128	1"	3	<b>1</b>

Ref.				Ø	Nº	Type
<b>1U-1531</b>	30	360	660	19	4	<b>1</b>
<b>4T-9126</b>	30	360	655	19	3	<b>3</b>
<b>1U-0599</b>	30	360	976	1"	3	<b>1</b>
<b>1U-0600</b>	30	360	1.079	1"	3	<b>1</b>
<b>1U-0601</b>	30	360	1.210	1"	3	<b>1</b>
<b>1U-1469</b>	30	360	841	1"	3	<b>1</b>
<b>1U-1470</b>	30	360	991	1"	4	<b>1</b>
<b>1U-1471</b>	30	360	1.121	1"	4	<b>1</b>
<b>1U-1473</b>	30	360	1.140	1"	4	<b>1</b>
<b>1U-1475</b>	30	360	756	1"	4	<b>2</b>
<b>1U-1478</b>	30	360	1.416	1"	8	<b>2</b>
<b>1U-1479</b>	30	360	1.067	1"	6	<b>2</b>
<b>1U-2410</b>	30	360	960	1"	3	<b>1</b>
<b>1U-2411</b>	30	360	1.056	1"	3	<b>1</b>
<b>1U-2412</b>	30	360	1.148	1"	3	<b>1</b>
<b>1U-2413</b>	30	360	1.162	1"	3	<b>1</b>
<b>1U-2414</b>	30	360	1.044	1"	3	<b>1</b>
<b>1U-0591</b>	30	360	1.106	1" 1/4	3	<b>1</b>
<b>1U-0593</b>	30	360	1.319	1" 1/4	3	<b>1</b>
<b>1U-1909</b>	30	360	1.260	1" 1/4	3	<b>1</b>
<b>1U-2406</b>	30	360	1.231	1" 1/4	3	<b>1</b>
<b>1U-2407</b>	30	360	1.223	1" 1/4	3	<b>1</b>
<b>1U-2408</b>	30	360	1.018	1" 1/4	3	<b>1</b>
<b>1U-2409</b>	30	360	1.205	1" 1/4	3	<b>1</b>
<b>4T-9125</b>	30	360	655	1" 1/4	3	<b>3</b>
<b>4T-9127</b>	30	360	637	1" 1/4	4	<b>3</b>
<b>4T-9128</b>	30	360	637	1" 1/4	4	<b>3</b>
<b>4T-9185</b>	30	360	572	1" 1/4	4	<b>4</b>
<b>7T-5960</b>	30	360	537	1" 1/4	4	<b>3</b>

Sub-Loader Blades

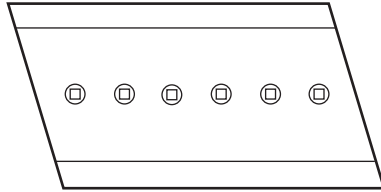

Fig 3

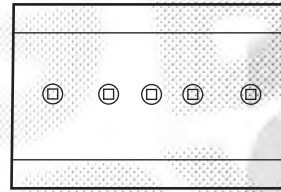
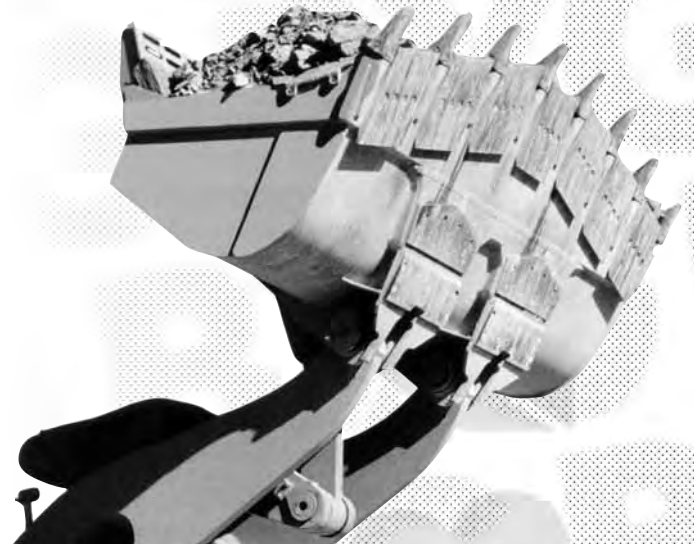











Fig 4

Ref.				Ø	Nº	Type
7T-5961	30	360	629	1" 1/4	4	3
7T-5962	30	360	528	1" 1/4	4	4
7T-5963	30	360	630	1" 1/4	4	3
7T-5964	30	360	537	1" 1/4	4	3
1U-1476	30	360	1.404	1" 1/4	8	2
4T-6588	35	406	1.211	1"	6	1
4T-6589	35	406	1.667	1"	8	2
4T-6590	35	406	859	1"	4	2
4T-6592	35	406	858	1"	4	2
4T-6594	35	406	1.542	1"	8	2
1U-0762	35	406	1.406	1" 1/4	3	1
4T-5273	35	406	1.337	1" 1/4	3	1
4T-7141	35	406	620	1" 1/4	4	4
4T-7142	35	406	682	1" 1/4	4	3
4T-7143	35	406	682	1" 1/4	4	3
4T-7144	35	406	735	1" 1/4	4	3
4T-7145	35	406	735	1" 1/4	4	3
9W-1375	35	406	1.524	1" 1/4	3	1
9W-3676	45	406	917	1" 1/4	4	2
9W-3677	45	406	927	1" 1/4	6	3
9W-3678	45	406	927	1" 1/4	6	3
9W-9943	20	425	1.231	7/8"	4	1
4T-7185	35	483	791	1" 1/4	6	3
4T-7186	35	483	791	1" 1/4	6	3
4T-7187	35	483	731	1" 1/4	5	3
4T-7188	35	483	731	1" 1/4	5	3
4T-7190	35	483	706	1" 1/4	5	4
9W-8249	35	483	1.105	1" 1/4	4	2
9W-8250	35	483	1.464	1" 1/4	3	1



## Loader Blades

			End Bit	Adapter	Type		Segments	Type		Sub-Loader	Type		Wear Plate
<b>994</b>	8X-0808	8X-0813/6	4T-4704 4T-4705 4T-4706		two strap	<b>70</b>	8E-3157 (2) 8E-3158 (3) 8E-3159 (3)	cent R L	6V-8360 (40) 3K-9770 (40)				8E-3160 (2)
<b>992</b>	9V-0009	3V-3893/4	7J-9554		flush	<b>55</b>							
<b>992</b>	3V-3890 9V-0007	3V-3893/4	3G-9494 3G-4554		two strap flush	<b>55</b>							
<b>992</b>	9V-0008	3V-3893/4	7J-9554 7J-9555 7J-9556		flush	<b>55</b>							
<b>992</b>	3V-3234 9V-0005 9V-0006 9V-3566 9V-3570	9V-6132	3G-9494 3G-9495 3G-9496 3G-4554 3G-4555 3G-4556		two strap flush	<b>55</b>	4T-6760 (1) 4T-6761 (3) 4T-6762 (3)	cent R L	5P-8823 (28) 3K-9770 (28)				
<b>992</b>	4E-6462	4E-6385	3G-9494 3G-9495 3G-9496 3G-4554 3G-4555 3G-4556		two strap flush	<b>55</b>	4T-6760 (1) 4T-6761 (3) 4T-6762 (3)	cent R L	5P-8823 (28) 3K-9770 (28)				1U-4933 (2)
<b>988</b>	8K-5056 8K-6588	7K-9309	7T-8454		flush	<b>45</b>							
<b>988</b>	9C-2932 9V-0232	2V-4314	4T-7454 7T-8454		two strap flush	<b>45</b>	9W-5734 (7)	cent	6V-6335 (21) 3K-9770 (21)				
<b>988</b>	8V-9583 8V-9585 8R-4649 6W-9311	2V-4314	4T-7454 4T-7455 4T-7456 7T-8454 7T-8455 7T-8456		two strap flush	<b>45</b>	9W-5734 (7) 9W-5737 (3) 9W-5730 (3)	cent R L	6V-6335 (21) 3K-9770 (21)	9W-5732 9W-5731 9W-5733 9W-5736 9W-5735	L cen L cen cen R R	6V-6335 (25) 3K-9770 (25)	1U-4929 (2)
<b>983</b>	8K-5000 8K-5056	7K-9309/10	4T-7454 7T-8454		two strap flush	<b>45</b>							
<b>983</b>	9K-5408 8V-9591	3V-3310/11	4T-7454 4T-7455 4T-7456 7T-8454 7T-8455 7T-8456		two strap flush	<b>45</b>							
<b>983</b>	9V-0235 9V-0237	3V-3310/11	7T-8454		flush	<b>45</b>							
<b>980</b>	9K-1619	7K-9309/10	3G-2357 (8) 1U-1354 (8) 1U-1350 (8)		bolt-on flush bottom strap	<b>35</b>			4T-6594 (1) 4T-6592 (2)	cen cen R		4J-9208 (16) 2J-3507 (16)	
<b>980</b>	2V-6118 2V-6286	2V-6299 (2)	1U-1354		flush	<b>35</b>							
<b>980</b>	6W-2991	7V-4180/1	1U-1357 (6) 1U-1358 / 9		bolt-on corner adap	<b>35</b>	4T-6700 (7)	cent	5P-8823 (14) 3K-9770 (14)	4T-5273(2) 1U-0761 (2) 1U-0764	cen corner cor ang	5P-8823 (12) 3K-9770 (12)	
<b>980</b>	7V-4188 7V-0909 9V-6574	7V-4180	1U-1357 (6) 1U-1358 / 9		bolt-on corner adap	<b>35</b>	4T-6700 (7)	cent	5P-8823 (14) 3K-9770 (14)	1U-0762 (2) 1U-0761 (2) 1U-0764	cen corn cor ang	5P-8823 (12) 3K-9770 (12)	
<b>980</b>	8V-9580 8V-9581 9V-3561 4E-6807					<b>35</b>	4T-3015 (1) 4T-7139 (3) 4T-7140 (3)	cent R L	6V-6535 (14) 3K-9770 (14)	4T-7141 4T-7144 4T-7145 4T-7142 4T-7143	cen cen R R corner cor ang	6V-6535 (18) 3K-9770 (18)	

		End Bit	Adapter	Type	Segments	Type		Sub-Loader	Type		Wear Plate
9K-8472 1V-	9K-8472 1V-9018	1V-8664 (2)	1U-1354 1U-1350	flush bottom strap	<b>35</b>						
<b>977</b>	7V-0898	4V-7174/5	3G-3357 (6) 3G-5358/9	bolt-on corner adap	<b>35</b>			1U-2409 (2) 3G-6395 (2) 1U-1897 (2)	cen corner cor ang	5P-8823 (12) 3K-9770 (12)	
<b>977</b>	6W-2983	4V-7174/5	3G-3357 (6) 3G-5358/9	bolt-on corner adap	<b>35</b>	4T-6696 (7)	cent	5P-8823 (14) 3K-9770 (14)	1U-2408 (2) 3G-6395 (2) 1U-1897 (2)	cen corner cor ang	5P-8823 (12) 3K-9770 (12)
<b>973</b>	6W-2982	4V-7174/5	3G-3357 (6) 3G-5358/9	bolt-on corner adap	<b>35</b>	4T-6697 (7)	cent	5P-8823 (12) 3K-9770 (12)	1U-0591 (2) 3G-6395 (2) 1U-1897 (2)	cen corner cor ang	5P-8823 (12) 3K-9770 (12)
<b>973</b>	6W-2981	4V-7174/5	3G-3357 (6) 3G-5358/9	bolt-on corner adap	<b>35</b>	4T-6698 (7)	cent	5P-8823 (12) 3K-9770 (12)	1U-0592 (2) 3G-6395 (2) 1U-1897 (2)	cen corner cor ang	5P-8823 (12) 3K-9770 (12)
<b>977</b>	9V-0171 9V-0178	8K-7525/6	1U-1354 (8) 1U-1350 (8)	flush bottom strap	<b>35</b>						
<b>977</b>	6W-2994	8K-7525/6	1U-1354 (7) 1U-1350 (7)	flush bottom strap	<b>35</b>	4T-3015 (2) 4T-9123 (2) 4T-9124 (2)	cent R L	6V-6535 (12) 3K-9770 (12)	9W-3676 9W-3678 9W-3677	cen corner cor ang	6V-6535 (12) 3K-9770 (12)
<b>966</b>	6W-2989	5V-2772/3	3G-9307 (6) 3G-8308/9	bolt-on corner adap	<b>30</b>	4T-6698 (7)	cent	5P-8823 (14) 3K-9770 (14)	1U-2407 (2) 3G-6395 (2) 1U-1897 (2)	cen corner cor ang	5P-8823 (12) 3K-9770 (12)
<b>966</b>	6W-2990	5V-2772/3	3G-9307 (6) 3G-8308/9	bolt-on corner adap	<b>30</b>	4T-6698 (7)	cent	5P-8823 (14) 3K-9770 (14)	1U-2406 (2) 3G-6395 (2) 1U-1897 (2)	cen corner cor ang	5P-8823 (12) 3K-9770 (12)
<b>966</b>	7V-0912 7V-1490 9V-6575	4V-7174/5	3G-3357 (6) 3G-5358/9	bolt-on corner adap	<b>35</b>	4T-6699 (7)	cent	5P-8823 (14) 3K-9770 (14)	1U-0593 (2) 3G-6395 (2) 1U-1897 (2)	cen corner cor ang	5P-8823 (12) 3K-9770 (12)
<b>966</b>	7V-6844	4V-7174/5	3G-3357 (6) 3G-5358/9	bolt-on corner adap	<b>35</b>				1U-1909 (2) 3G-6395 (2) 1U-1897 (2)	cen corner cor ang	5P-8823 (12) 3K-9770 (12)
<b>966</b>	1V-3917 2V-3583 6W-5520	1V-8664 (2)	1U-1354 1U-1350	flush bottom strap	<b>35</b>						
<b>966</b>	9V-0170 9V-0176	8K-7525/6	1U-1354 1U-1350	flush bottom strap	<b>35</b>						
<b>966</b>	6W-2993	8K-7525/6	1U-1354 1U-1350	flush bottom strap	<b>35</b>	4T-6697 4T-9123 (3) 4T-9124 (3)	cent R L	6V-6535 (14) 3K-9770 (14)	4T-9127 4T-9125 4T-9185 4T-9126 4T-9128	L cen L cen cen R R	6V-6535 (18) 3K-9770 (18)
<b>963</b>	6W-2979	5V-1783	4T-4307 (6) 3G-4308/9	bolt-on corner adap	<b>30</b>	4T-6692 (5) 4T-6693 4T-6693	cent R L	4F-4042 (14) 2J-3507 (14)	1U-0599 (2) 4T-8101 (2) 1U-1898 (2)	cen corner cor ang	4F-4042 (14) 2J-3507 (14)
<b>963</b>	6W-2980	5V-1783	4T-4307 (6) 3G-4308/9	bolt-on corner adap	<b>30</b>	4T-6694 (7)	cent	4F-4042 (14) 2J-3507 (14)	1U-0600 (2) 4T-8101 (2) 1U-1898 (2)	cen corner cor ang	4F-4042 (14) 2J-3507 (14)
<b>955</b>	5V-7263	5V-1783/4	4T-4307 (6) 3G-4308/9	bolt-on corner adap	<b>30</b>				1U-2411 (2) 4T-8101 (2) 1U-1898 (2)	cen corner cor ang	4F-4042 (14) 2J-3507 (14)
<b>955</b>	5V-7437	8K-6455/6	1U-0307 (8) 1U-1304 9J-8929	bolt-on flush bottom strap	<b>30</b>				1U-1471 1U-1471	L R	4F-4042 (12) 2J-3507 (12)
<b>955</b>	6W-2978	5V-1783/4	4T-4307 (6) 3G-4308/9	bolt-on corner adap	<b>30</b>	4T-6692 (7)	cent	4F-4042 (14) 2J-3507 (14)	1U-2410 (2) 4T-8101 (2) 1U-1898 (2)	cen corner cor ang	4F-4042 (14) 2J-3507 (14)
<b>953</b>	9V-6570	4V-1544/5	1U-0257 (6) 3G-4258/9	bolt-on corner adap	<b>25</b>	4T-6692 (7)	cent	1J-5607 (14) 2J-3507 (14)	1U-0293 (2) 4T-8091 (2) 1U-1896 (2)	cen corner cor ang	1J-5607 (10) 2J-3507 (10)
<b>953</b>	9V-6572	4V-1544/5	1U-0257 (6) 3G-4258/9	bolt-on corner adap	<b>25</b>	4T-6694 (7)	cent	1J-5607 (14) 2J-3507 (14)	1U-0295 (2) 4T-8091 (2) 1U-1896 (2)	cen corner cor ang	1J-5607 (10) 2J-3507 (10)
<b>951</b>	6W-2977	4V-1544/5	1U-0257 (6) 3G-4258/9	bolt-on corner adap	<b>25</b>	4T-6691 (7)	cent	1J-5607 (14) 2J-3507 (14)	1U-0605 (2) 4T-8091 (2) 1U-1896 (2)	cen corner cor ang	1J-5607 (12) 2J-3507 (12)
<b>951</b>	5V-4670 9V-6572	4V-1544/5	1U-0257 (6) 3G-4258/9	bolt-on corner adap	<b>25</b>	4T-6694 (7)	cent	1J-5607 (14) 2J-3507 (14)	1U-0295 (2) 4T-8091 (2) 1U-1896 (2)	cen corner cor ang	1J-5607 (10) 2J-3507 (10)
<b>951</b>	9K-8471 1V-0074	4V-8285/6	1U-1254 3G-0169	flush bottom strap	<b>25</b>						

		End Bit	Adapter	Type		Segments	Type		Sub-Loader	Type		Wear Plate
<b>950</b>	5V-4696 5V-7410 9V-6573	5V-1783/4	4T-4307 (6) 3G-4308/9	bolt-on corner adap	<b>30</b>	4T-6695 (7)	cent	4F-4042 (14) 2J-3507 (14)	1U-0601 (2) 4T-8101 (2) 1U-1898 (2)	cen corner cor ang	4F-4042 (12) 2J-3507 (12)	
<b>950</b>	6W-2986	5V-7395/6	1U-0307 (6) 3G-4308/9	bolt-on corner adap	<b>30</b>	4T-6694 (5) 4T-6693 4T-6693	cent R L	1J-5607 (14) 2J-3507 (14)	1U-2414 (2) 4T-8101 (2) 1U-1898 (2)	cen corner cor ang	4F-4042 (12) 2J-3507 (12)	
<b>950</b>	6W-987	5V-7395/6	1U-0307 (6) 3G-4308/9	bolt-on corner adap	<b>30</b>	4T-6694 (5) 4T-6695 4T-6695	cent R L	1J-5607 (14) 2J-3507 (14)	1U-2412 (2) 4T-8101 (2) 1U-1898 (2)	cen corner cor ang	4F-4042 (12) 2J-3507 (12)	
<b>950</b>	6W-2988	5V-7395/6	1U-0307 (6) 3G-4308/9	bolt-on corner adap	<b>30</b>	4T-6694 (5) 4T-6695 4T-6695	cent R L	1J-5607 (14) 2J-3507 (14)	1U-2413 (2) 4T-8101 (2) 1U-1898 (2)	cen corner cor ang	4F-4042 (12) 2J-3507 (12)	
<b>950</b>	6W-2973 6W-9879 9C-0967	5W-3468 (2)	1U-1354 1U-1350	flush bottom strap	<b>35</b>	4T-3015 4T-9123 (3) 4T-9124 (3)	cent R L	8T-9079 (14) 3K-9770 (14)	7T-5964 7T-5961 7T-5962 7T-5963 7T-5960	L cen L cen cen R R	8T-9079 (18) 3K-9770 (14)	
<b>950</b>	1V-3915 1V-396 7V-7416	8K-6455/6	1U-1304 9J-8929	flush bottom strap	<b>30</b>							
<b>943</b>	9V-6571	4V-1544/5	1U-0257 (6) 3G-4258/9	bolt-on corner adap	<b>25</b>	4T-6692 (5) 4T-6693 4T-6693	cent R L	1J-5607 (14) 2J-3507 (14)	4T-9563 (2) 1J-5607 (14) 2J-3507 (14) 4T-8091 (2) 1U-1896 (2)	L cen R corner cor ang	1J-5607 (10) 2J-3507 (10)	
<b>943</b>	9V-6570	4V-1544/5	1U-0257 (6) 3G-4258/9	bolt-on corner adap	<b>25</b>	4T-6892 (7)	cent	1J-5607 (14) 2J-3507 (14)	1U-0293 (2) 4T-8091 (2) 1U-1896 (2)	cen corner cor ang	1J-5607 (10) 2J-3507 (10)	
<b>943</b>	9V-6571	4V-1544/5	1U-0257 (6) 3G-4258/9	bolt-on corner adap	<b>25</b>	4T-6691 (7)	cent	1J-5607 (14) 2J-3507 (14)	1U-0294 (2) 4T-8091 (2) 1U-1896 (2)	cen corner cor ang	1J-5607 (10) 2J-3507 (10)	
<b>941</b>	9K-8471 1V-0074	4V-8285/6	1U-1254 3G-0169	flush bottom strap	<b>25</b>							
<b>941</b>	5V-4670 9V-6572	4V-1544/5	1U-0257 (6) 3G-4258/9	bolt-on corner adap	<b>25</b>	4T-6694 (7)	cent	1J-5607 (14) 2J-3507 (14)	1U-0295 (2) 4T-8091 (2) 1U-1896 (2)	cen corner cor ang	1J-5607 (10) 2J-3507 (10)	
<b>941</b>	6W-2977	4V-1544/5	1U-0257 (6) 3G-4258/9	bolt-on corner adap	<b>25</b>	4T-6691 (7)	cent	1J-5607 (14) 2J-3507 (14)	1U-0605 (2) 4T-8091 (2) 1U-1896 (2)	cen corner cor ang	1J-5607 (10) 2J-3507 (10)	
<b>936</b>	8V-1825 6W-2985	4V-1544/5	1U-0257 (6) 3G-4258/9	bolt-on corner adap	<b>25</b>	4T-6695 (7)	cent	1J-5607 (14) 2J-3507 (14)	1U-0292 (2) 4T-8091 (2) 1U-1896 (2)	cen corner cor ang	1J-5607 (10) 2J-3507 (10)	
<b>935</b> <b>941</b>	5G-2808	5G-2806/7	9J-4207 (6) 1U-2208/9	bolt-on corner adap	<b>20</b>				4T-2911 4T-2910 (2)	cen corner	4F-7827 (8) 2J-3506 (8)	
<b>935</b> <b>941</b>	5G-3085	5G-2806/7	9J-4207 (6) 1U-2208/9	bolt-on corner adap	<b>20</b>				4T-2913 4T-2914 (2)	cen corner	4F-7827 (7) 2J-3506 (7)	
<b>930</b>	6W-2984	4V-1544/5	1U-0257 (6) 3G-4258/9	bolt-on corner adap	<b>25</b>	4T-6694 (5) 4T-6693 4T-6693	cent R L	1J-5607 (14) 2J-3507 (14)	1U-0607 (2) 4T-8091 (2) 1U-1896 (2)	cen corner cor ang	1J-5607 (10) 2J-3507 (10)	
<b>926</b>	5V-4670 9V-6572	4V-1544/5	1U-0257 (6) 3G-4258/9	bolt-on corner adap	<b>25</b>	4T-6694 (7)	cent	1J-5607 (10) 2J-3507 (10)	1U-0295 (2) 4T-8091 (2) 1U-1896 (2)	cen corner cor ang	1J-5607 (14) 2J-3507 (10)	
<b>920</b>	6W-2984	4V-1544/5	1U-0257 (6) 3G-4258/9	bolt-on corner adap	<b>25</b>	4T-6694 (5) 4T-6693 4T-6693	cent der izq	1J-5607 (14) 2J-3507 (14)	1U-0607 (2) 4T-8091 (2) 1U-1896 (2)	cen corner cor ang	1J-5607 (10) 2J-3507 (10)	
<b>916</b>	5V-4670 9V-6572	4V-1544/5	1U-0257 (6) 3G-4258/9	bolt-on corner adap	<b>25</b>	4T-6694 (7)	cent	1J-5607 (14) 2J-3507 (14)	1U-0295 (2) 4T-8091 (2) 1U-1896 (2)	cen corner cor ang	1J-5607 (10) 2J-3507 (10)	
<b>910</b>	5G-3085 5G-6133	5G-2806/7	9J-4207 (5) 1U-2208/9 4T-1204 8J-7525	bolt-on corner adap flush bottom strap	<b>20</b>	7T-8935 (6)	cent	4F-7827 (7) 2J-3506 (7)	4T-2913 4T-2914 (2)	cen corner	4F-7827 (7) 2J-3506 (7)	





Armoured Bars

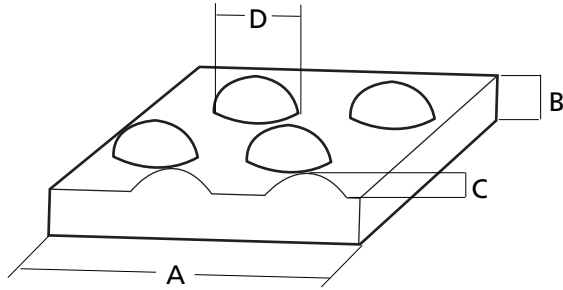

500HB

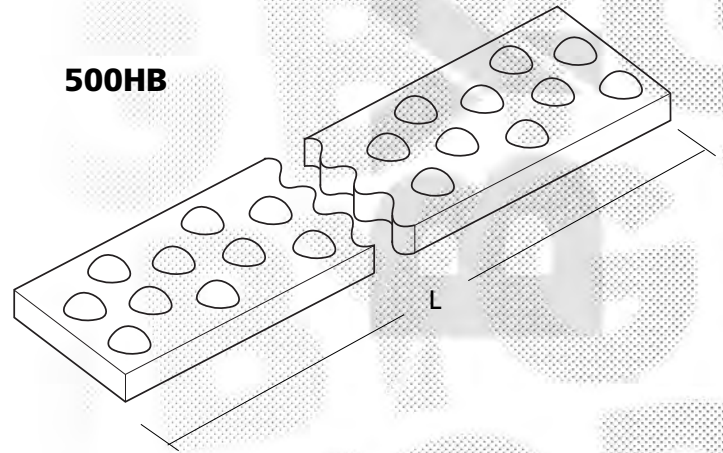

	mm.				L (mm.)	
	A	B	C	D		
<b>BLI-10</b>	80	10	2,5	22	3000	7,1 Kg/m.
<b>BLI-15</b>	100	15	3,0	25	3000	13,0 Kg/m.
<b>BLI-20</b>	120	20	3,5	28	3000	20,0 Kg/m.

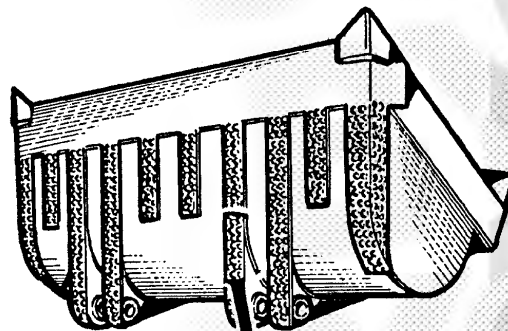
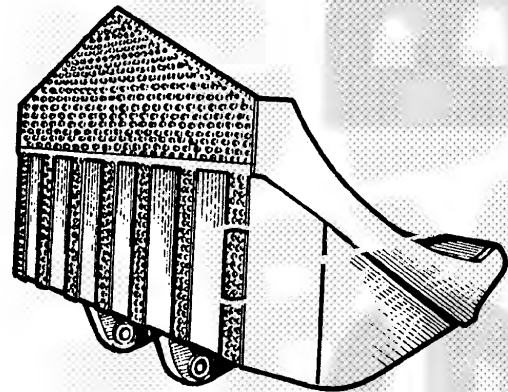
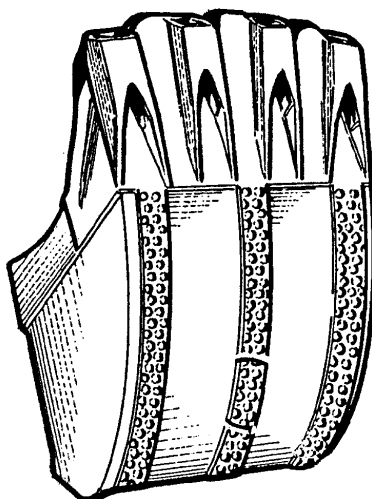

## Grouser Bars to Rebuild Shoes

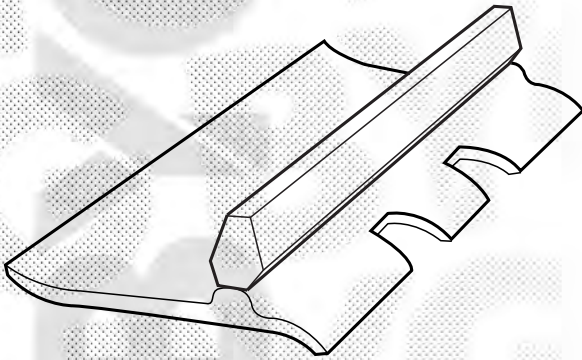

BYG weld-on grouser bars are made of high quality steel to rebuild the worn shoes without the need of replacing the whole unit.

### Major Yield

Worn shoes may make the machine slip and lose traction and consequently waste time and fuel. By rebuilding the shoes your machine will get back the original yield.

### Economy

The shape and special design of the grouser bar will ensure a quick and economical welding with a perfect finish saving a lot of material.

**450 HB**

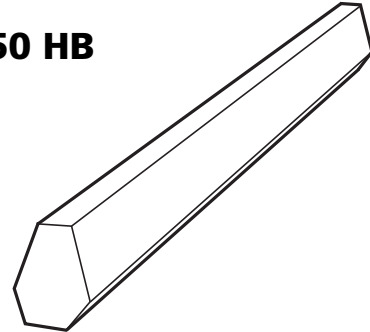

### Sizes

The BYG grouser bar is designed to fit the original shoe. Depending on the wear of your shoes you will be able to choose between various sizes available at BYG.

### Specifications

BYG grouser bars are made of SAE 1070 steel with a hardness of the treated bar of 450HB.

Ref.	Applications	Area mm <sup>2</sup>	Weight Kg/m	Height mm.	Width mm.	m / ton.
<b>RT-0198</b>	Tractores Agrícolas	252	1,98	22,00	14,00	505
<b>RT-0225</b>	955H, 955K, 955L, D60S	287	2,25	18,00	19,00	444
<b>RT-0335</b>	FL12, FL14, 977	427	3,35	21,00	24,00	298
<b>RT-0339</b>	D4, D5, D6	432	3,39	34,92	15,88	295
<b>RT-0423</b>	D5, D6, AD7, D50	539	4,23	38,10	19,05	236
<b>RT-0545</b>	D6, AD7	694	5,45	38,00	23,00	183
<b>RT-0794</b>	D7F, D7G, D8H, D8K, AD20, D155	1011	7,94	44,45	28,50	126
<b>RT-0945</b>	D7F, D7G, D8H, D8K, AD20	1204	9,45	44,45	31,75	106
<b>RT-1297</b>	D9H, D9G, HD41, D355	1652	12,97	60,00	35,00	77
<b>RT-1701</b>	D9L, D10N, D375,, D455	2167	17,01	68,00	37,00	59
<b>RT-2110</b>	D10, D11, D455, D475	2690	21,10	76,00	43,00	47

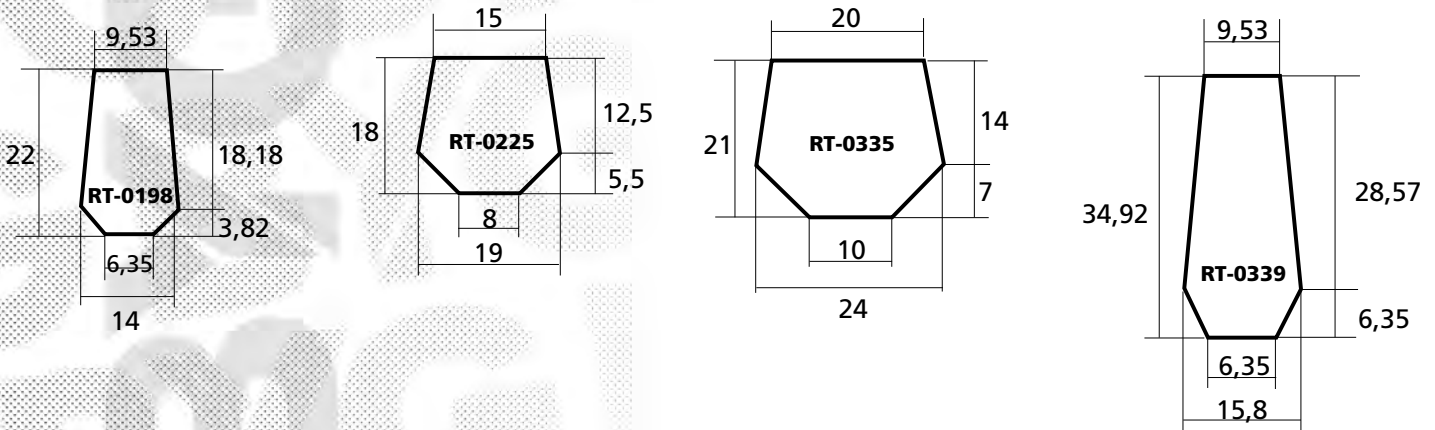

Grouser Bars to Rebuild Shoes

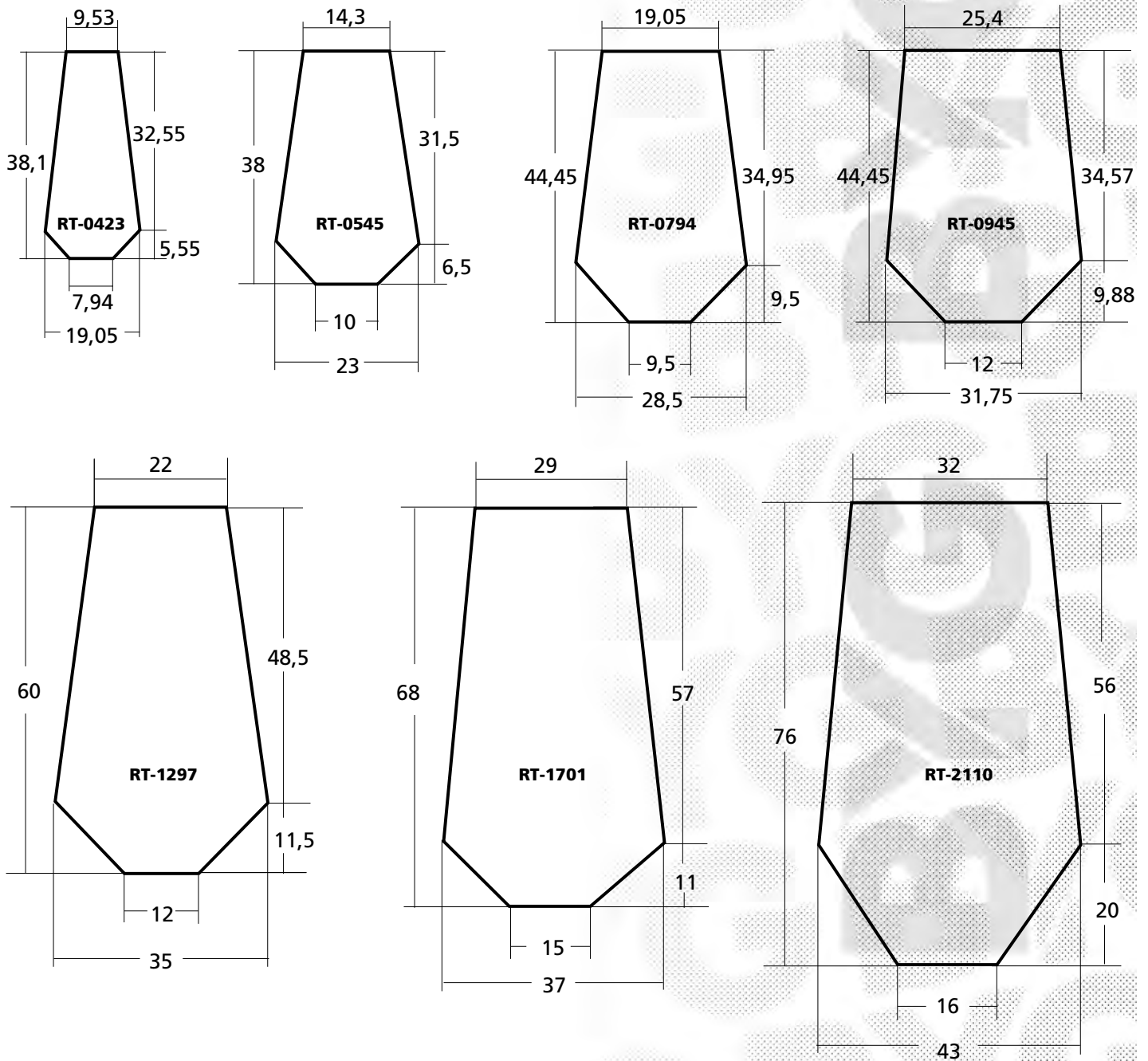

# Shoes per model	Width of Shoe, meters needed									
	203 mm	305 mm	330 mm	356 mm	381 mm	406 mm	457 mm	508 mm	559 mm	610 mm
58	11,9 m	17,9 m	19,3 m	20,8 m	22,3 m	23,7 m	26,7 m	29,6 m	32,6 m	35,6 m
60	12,4 m	18,5 m	20,0 m	21,5 m	23,0 m	24,5 m	27,6 m	30,7 m	33,7 m	36,8 m
62	12,8 m	19,1 m	20,6 m	22,3 m	23,8 m	25,4 m	28,5 m	31,7 m	34,8 m	38,0 m
64	13,2 m	19,7 m	21,3 m	23,0 m	24,6 m	26,2 m	29,4 m	32,7 m	36,0 m	39,2 m
66	13,6 m	20,3 m	22,0 m	23,7 m	25,3 m	27,0 m	30,4 m	33,7 m	37,1 m	40,5 m
68	14,0 m	20,9 m	22,6 m	24,4 m	26,1 m	27,8 m	31,3 m	34,7 m	38,2 m	41,7 m
70	14,4 m	21,6 m	23,3 m	25,1 m	26,9 m	28,6 m	32,2 m	35,8 m	39,3 m	42,9 m
72	14,8 m	22,2 m	24,0 m	25,8 m	27,6 m	29,4 m	33,1 m	36,8 m	40,5 m	44,1 m
74	15,2 m	22,8 m	24,6 m	26,6 m	28,4 m	30,3 m	34,0 m	37,8 m	41,6 m	45,4 m
76	15,7 m	23,4 m	25,3 m	27,3 m	29,2 m	31,1 m	35,0 m	38,8 m	42,7 m	46,6 m
78	16,1 m	24,0 m	26,0 m	28,0 m	30,0 m	31,9 m	35,9 m	39,9 m	43,8 m	47,8 m



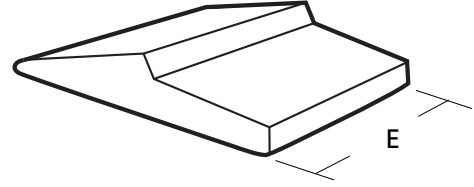
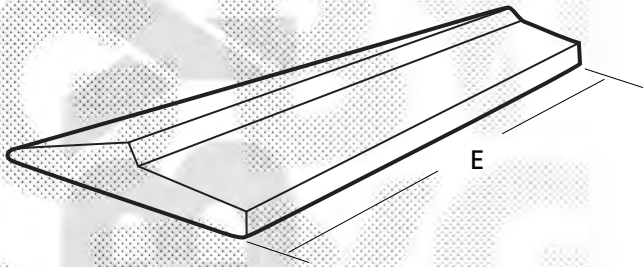

Cutting Edge: Half Arrow Edge Profiles

500 HB

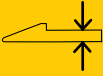

EEEE = 4 digits indicating the length of the profile (multiples of 50mm.)  
 Max. length: 6000 mm. See page 37: Codification of Half Arrow Profiles

		
10mm.	100mm.	<b>F5210100</b> __
15mm.	150mm.	<b>F5215150</b> __
20mm.	200mm.	<b>F5220200</b> __
30mm.	250mm.	<b>F5230250</b> __

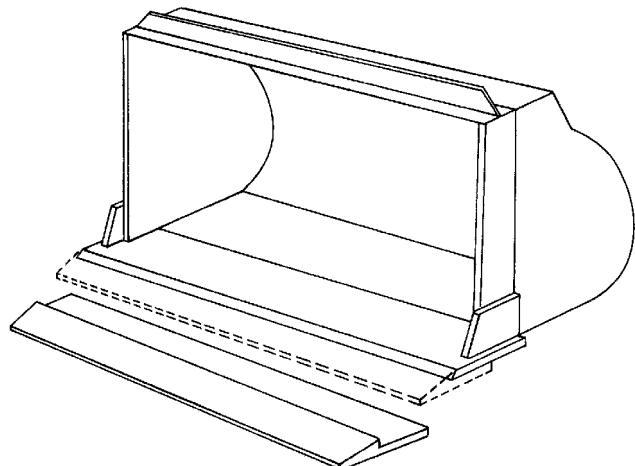
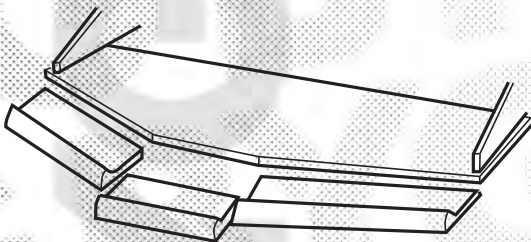
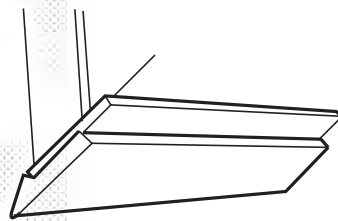
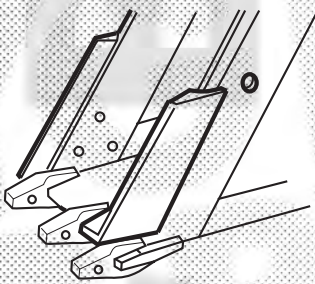

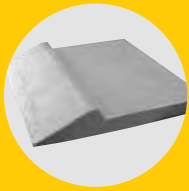

# Codification of Half Arrow Profiles

The reference number of the profiles are composed of 5 blocks of characters. Each block indicates a characteristic.

**BB CC DDD EEEE**

(12 characters without blank spaces)

**A**

The first block (one character) indicates the type of part.

F HALF ARROW PROFILE

Example:

**F \*\* \*\* \*\* \***

**BB**

The second block (2 characters) indicates the quality of the part (Brinell scale), as shown.

52 520 Brinell

Example:

**F 52 \*\* \*\* \***

**CC**

The third block (2 digits) indicates the shank thickness. The digits correspond exactly to the thickness (millimeters) with the exception of: 100mm, 110mm and 120mm,, as shown in the following list:

- 10 10mm. Thickness (520 Brinell)
- 15 15mm. Thickness (520 Brinell)
- 20 20mm. Thickness (520 Brinell)
- 30 30mm. Thickness (520 Brinell)

Example:

**F 52 15 \*\*\* \*\* \***

**DDD**

This block (3 digits) indicates the width of the profiles, in millimeters.

- 100mm. width (10 mm Thickness)
- 150mm. width (15 mm Thickness)
- 200mm. width (20 mm Thickness)
- 250mm. width (30 mm Thickness)

Example:

**F 52 15 150 \*\*\* \***

**EEEE**

The last block (4 digits) indicates the length (in millimeters) of the profile, always in multiples of 50 mm.

Ejemplo:

**F 52 15 150 6000**

Reference example (12 characters without blank spaces)

**F52151505000**

Type    Quality    Thickness    Width    Length

## Safety Hook Weld-on

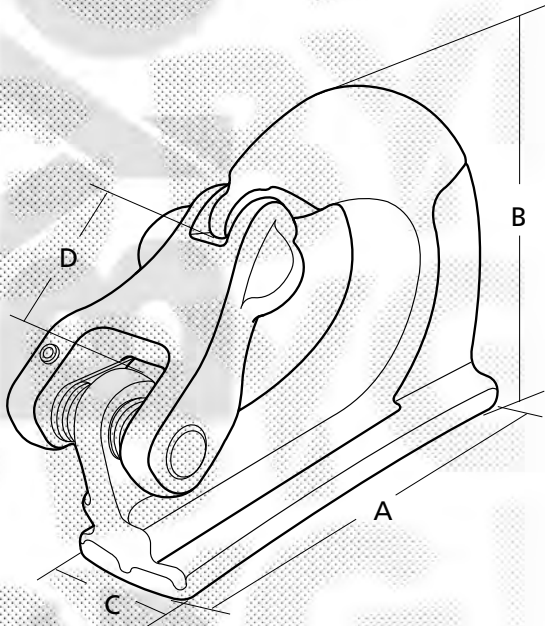

mm.				Kg.		Size
A	B	C	D			
95	73	25	22	0,56 1,2 lbs.	<b>GH-1000</b>	1
114	88	30	29	0,96 2,1 lbs.	<b>GH-2000</b>	2
133	106	35	29	1,36 3 lbs.	<b>GH-3000</b>	3
142	112	42	31	1,89 4,1 lbs.	<b>GH-4000</b>	4
166	131	45	34	2,80 6,1 lbs.	<b>GH-5000</b>	5
173	133	50	35	3,50 7,7 lbs.	<b>GH-8000</b>	8
221	170	56	50	6,20 13,6 lbs.	<b>GH-10000</b>	10



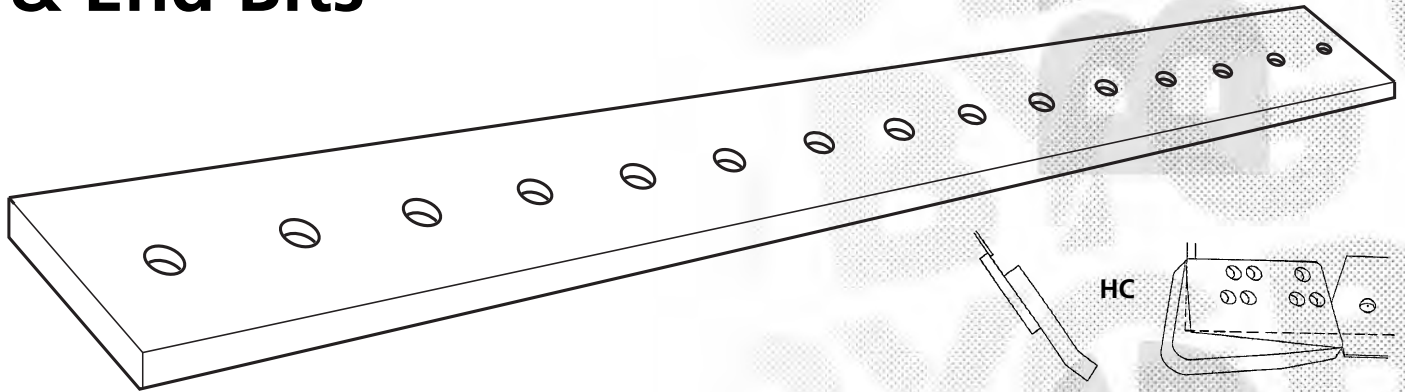

# DRP Komatsu

## Cutting Edges & End Bits















### Komatsu Dozer Cutting Edges







	Type	Series	Ref.	Inches		mm.			Description	n°	
					n°						
<b>D10-A</b>		1002-UP	<b>10A-71-11190</b>			10	76	1.349			
<b>D20A-3</b>	Angle	20007-UP	<b>101-71-12370</b>	1/2x2	11	16	152	1.670	Central Cutting Edge		26
<b>D21A-3</b>			<b>101-71-11190</b>	1/2x2	4	16	152	314	Straight Right End		5
			<b>101-71-11220</b>	1/2x2	4	16	152	314	Straight Left End		5
<b>D30A-12</b>	Angle	5002-UP	<b>112-70-31110</b>	5/8x2	13	16	152	1.999	Central Cutting Edge		30
<b>D30A-15</b>			<b>112-70-31130</b>	5/8x2	4	16	152	370	Straight Right End		5
			<b>112-70-31120</b>	5/8x2	4	16	152	370	Straight Left End		5
<b>D31A-16</b>	Angle Tilt	25001-UP	<b>114-72-21140</b>	5/8x2	6	16	152	841	Central Cutting Edge	2	13
			<b>112-946-1510</b>	5/8x2	4	16	152	370	Side Cutting Edge		5
			<b>112-946-1510RHD</b>	5/8x2	4				Right HC End		12
			<b>112-946-1510LHD</b>	5/8x2	4				Left HC End		12
<b>D31P-16</b>	Straight Tilt	25001-UP	<b>11G-71-21170</b>	5/8x2	6	16	152	870	Central Cutting Edge	2	13
			<b>112-946-1510</b>	5/8x2	4	16	152	370	Side Cutting Edge		5
			<b>112-946-1510RHD</b>	5/8x2	4				Right HC End		12
			<b>112-946-1510LHD</b>	5/8x2	4				Left HC End		12
			Angle Tilt	25001-UP	<b>12F-70-11640</b>	5/8x2	8	16	152	1.199	Central Cutting Edge
	<b>112-946-1510</b>	5/8x2			4	16	152	370	Side Cutting Edge		5
	<b>112-946-1510RHD</b>	5/8x2			4				Right HC End		12
			<b>112-946-1510LHD</b>	5/8x2	4			Left HC End		12	
<b>31P</b>	Angle Tilt		<b>12F-70-31281</b>	5/8x2	8	16	152	1.218	Central Cutting Edge		21
		<b>12F-70-31261</b>	5/8x2	6	16	152	913	Central Cutting Edge	2	16	
		<b>120-Y46-5172</b>	5/8x2	4				Right HC End		7	
		<b>120-Y46-5162</b>	5/8x2	4				Left HC End		7	
<b>D31A</b>			<b>125-70-31261</b>	5/8	6	25	203	911	Central Cutting Edge	2	35
			<b>125-70-31251</b>	5/8	5	25	203	759			29
				5/8	4	25	203	368	Side Cutting Edge		14
<b>D31A-17</b>	Angle Tilt	32001-UP	<b>12F-70-31261</b>	5/8x2	6	16	152	897	Central Cutting Edge		16
			<b>12F-70-31251</b>	5/8x2	5	16	152	760	Central Cutting Edge	2	13

	Type	Series	Ref.	Inches	n°	mm.			Description	n°	
											
			<b>112-946-1510</b>	5/8x2	4	16	152	370	Side Cutting Edge		5
			<b>112-946-1510RHD</b>	5/8x2	4				Right HC End		12
			<b>112-946-1510LHD</b>	5/8x2	4				Left HC End		12
<b>D31A-17</b> <b>D31P-17A</b>	Angle Angle Tilt	32001-UP	<b>12F-70-31281</b>	5/8x2	6	16	152	1.218	Central Cutting Edge	2	21
			<b>12F-70-31261</b>	5/8x2	5	16	152	913	Central Cutting Edge	2	16
			<b>112-946-1510</b>	5/8x2	4	16	152	370	Side Cutting Edge		5
			<b>112-946-1510RHD</b>	5/8x2	4				Right HC End		12
			<b>112-946-1510LHD</b>	5/8x2	4				Left HC End		12
<b>D31P-17</b>	Straight Tilt	32001-UP	<b>12F-70-31261</b>	5/8x2	6	16	152	897	Central Cutting Edge	2	16
			<b>12F-70-31251</b>	5/8x2	5	16	152	760	Central Cutting Edge	2	13
			<b>11G-71-31170</b>	5/8x2	4	16	152	370	Side Cutting Edge		5
			<b>11G-71-31170RHD</b>	5/8x2	4				Right HC End		12
			<b>11G-71-31170LHD</b>	5/8x2	4				Left HC End		12
	Angle	32001-UP	<b>12F-70-31281</b>	5/8x2	8	16	152	1.218	Central Cutting Edge	2	21
			<b>112-946-1510</b>	5/8x2	4	16	152	370	Side Cutting Edge		5
			<b>112-946-1510RHD</b>	5/8x2	4				Right HC End		12
			<b>112-946-1510LHD</b>	5/8x2	4				Left HC End		12
<b>41A, 41P</b> <b>D40A-1</b> <b>D45A-1</b> <b>D45E-1</b>	Angle	1501-UP 1803-UP	<b>12F-70-31251</b>	5/8x2 1/4	5	16	152	760	Central Cutting Edge	2	13
			<b>12F-70-11640</b> <b>124-70-11640</b>	5/8x2 1/4	8	16	152	1.199	Central Cutting Edge	2	18
			<b>124-70-21340RF</b>	5/8x2 1/4	6	19	165	322	Straight Right End		7
			<b>124-70-21330RF</b>	5/8x3 1/4	4	19	165	322	Straight Left End		7
<b>D40-1</b> <b>D45A</b>	Straight		<b>124-70-21340</b>	5/8x2 1/4	6				Right HC End		10
			<b>124-70-21330</b>	5/8x3 1/4	4				Left HC End		10
			<b>124-920-1280</b>	5/8x2 1/4	6	16	152	919	Central Cutting Edge	2	14
			<b>130-817-1121</b>	5/8x2 1/4	6				Right HC End		10
<b>D40P-1</b> <b>D45P-1</b>	Straight Tilt Swamp	1501-2200 1501-1800	<b>130-817-1131</b>	5/8x3 1/4	4				Left HC End		10
			<b>12F-70-11640</b> <b>124-70-11640</b>	5/8x2 1/4	8	16	152	1.199	Central Cutting Edge	2	18
			<b>130-817-1121</b>	5/8x2 1/4	6				Right HC End		10
			<b>130-817-1131</b>	5/8x3 1/4	4				Left HC End		10
<b>D40A-3</b> <b>D41A-3</b> <b>D41E-3</b>	Angle Tilt	6001-UP	<b>12F-70-31281</b>	5/8x2 1/2	8	16	152	870	Central Cutting Edge	2	21
			<b>120-70-31411</b>	5/8x2 1/2	4	22	203	375	Side Cutting Edge		11
			<b>120-70-31411R</b>	5/8x2 1/2	4				Right HC End		12
			<b>120-70-31411L</b>	5/8x2 1/2	4				Left HC End		12
<b>D40A-1</b> <b>D45A-1</b> <b>D45E</b>	Straight Tilt Straight Tilt	1501-UP 1803-UP	<b>11G-71-21170</b>	5/8x2	6	16	152	870	Central Cutting Edge	2	13
			<b>124-70-21180RF</b>	5/8x2 1/4	6	19	165	322	Straight Right End		7
			<b>124-70-21170RF</b>	5/8x3 1/4	4	19	165	322	Straight Left End		7
			<b>124-70-21180</b>	5/8x2 1/4	6				Right HC End		10
			<b>124-70-21170</b>	5/8x3 1/4	4				Left HC End		10
<b>D40P-1</b> <b>D45P-1</b>		2201-UP 1801-UP	<b>12F-70-11640</b> <b>124-70-11640</b>	5/8x2 1/4	8	16	152	1.199	Central Cutting Edge	2	18
			<b>13F-A70-1580</b>	5/8x2 1/4	6				Right HC End		10
			<b>13F-A70-1570</b>	5/8x3 1/4	4				Left HC End		10
<b>D40A-3</b> <b>D41A-3</b>	Straight Straight Tilt	6001-UP	<b>12F-70-31261</b>	5/8x2 1/4	6	16	152	897	Central Cutting Edge	2	16
			<b>12F-70-31251</b>	5/8x2 1/4	5	16	152	760	Central Cutting Edge	2	13
			<b>120-70-31411RF</b>	5/8x2 1/4	4	22	203	375	Side Cutting Edge		11
			<b>120-70-31411RF</b>	5/8x2 1/4	4				Right HC End		12
			<b>120-70-31411L</b>	5/8x2 1/4	4				Left HC End		12
<b>D41E-3</b>	Straight Straight Tilt	6001-UP	<b>12F-70-31281</b>	5/8x2 1/4	8	16	152	1.218	Central Cutting Edge	2	21
			<b>12F-70-31251</b>	5/8x2 1/4	5	16	152	760	Central Cutting Edge	2	13
			<b>120-70-31411</b>	5/8x2 1/4	4	22	203	375	Side Cutting Edge		11















	Type	Series	Ref.	Inches		mm.			Description	n°	
					n°						
			<b>120-70-31411R</b>	5/8x2 1/4	4				Right HC End		12
			<b>120-70-31411L</b>	5/8x2 1/4	4				Left HC End		12
<b>D40F-3</b>	Straight	6221-UP	<b>12F-70-31281</b>	5/8x2 1/4	8	16	152	1.218	Central Cutting Edge	2	21
			<b>12F-70-31251</b>	5/8x2 1/4	5	16	152	760	Central Cutting Edge	2	13
			<b>112-946-1510</b>	5/8x2 1/4	4	16	152	370	Side Cutting Edge		5
			<b>112-946-1510RHD</b>	5/8x2 1/4	4				Right HC End		12
			<b>112-946-1510LHD</b>	5/8x2 1/4	4				Left HC End		12
<b>D41A-3A</b>	Angle Tilt	6001-UP	<b>12F-70-31261</b>	5/8x2 1/4	6	16	152	897	Central Cutting Edge	2	16
<b>D40P-3</b>	Straight	6001-UP	<b>12F-70-31251</b>	5/8x2	5	16	152	760	Central Cutting Edge	3	13
<b>D41P-3</b>	Straight Tilt		<b>112-946-1510</b>	5/8x2	4	16	152	370	Side Cutting Edge		5
<b>D40P-3</b>	Straight	6001-UP	<b>112-946-1510RHD</b>	5/8x2	4				Right HC End		12
<b>D41P-3</b>	Straight Tilt		<b>112-946-1510LHD</b>	5/8x2	4				Left HC End		12
<b>D40P-3</b>	Angle	6001-UP	<b>12F-70-31261</b>	5/8x2 1/4	6	16	152	897	Central Cutting Edge	3	16
			<b>112-946-1510</b>	5/8x2 1/4	4	16	152	370	Side Cutting Edge		5
			<b>112-946-1510RHD</b>	5/8x2 1/4	4				Right HC End		12
			<b>112-946-1510LHD</b>	5/8x2 1/4	4				Left HC End		12
<b>D50A-15</b>	Straight Tilt	35002-58999	<b>130-842-5120</b>	3/4	7	19	203	1.054	Central Cutting Edge	2	29
			<b>130-842-5120HD</b>	3/4	7	25	203	1.054	Central Cutting Edge	2	40
			<b>140-70-11141/11180</b>	3/4x3	6				Right HC End		18
			<b>140-70-11131/11170</b>	3/4x4 1/2	4				Left HC End		18
		59001-UP	<b>130-920-2180</b>	3/4	8	19	203	1.197	Central Cutting Edge	2	33
			<b>130-920-2180HD</b>	3/4	8	25	203	1.197	Central Cutting Edge	2	45
			<b>140-70-11141/11180</b>	3/4x3	6				Right HC End		18
			<b>140-70-11131/11170</b>	3/4x4 1/2	4				Left HC End		18
<b>D53A-15</b>		6001-UP	<b>130-70-41130</b>	3/4x2 3/4	9	19	203	1.349	Central Cutting Edge	2	38
			<b>130-70-41130HD</b>	3/4x2 3/4	9	29	25	203	Central Cutting Edge	2	51
			<b>140-70-11180</b>	3/4x4	4				Right HC End		18
			<b>140-70-11170</b>	3/4x2 3/4	6				Left HC End		18
<b>D50A-SP-15</b>	Angle Swamp	35002	<b>130-70-41130</b>	3/4x3	9	19	203	1.349	Central Cutting Edge	2	38
<b>D50A-15 P-15</b>	Angle Swamp	60107-UP	<b>130-70-41130HD</b>	3/4x3	9	25	203	1.349	Central Cutting Edge	2	51
<b>D53A-15</b>			<b>140-70-11141/11180</b>	3/4x3	6				Right HC End		18
<b>D50S-15</b>	Straight	35002-58999	<b>140-70-11131/11170</b>	3/4x4 1/2	4				Left HC End		18
<b>D50A-16</b>	Straight Tilt	65001	<b>130-Z20-1510</b>	3/4x2 3/4	8	19	203	1.254	Central Cutting Edge	2	35
<b>D53A-16 /A</b>	Straight		<b>130-Z20-1510HD</b>	3/4x2 3/4	8	25	203	1.254	Central Cutting Edge	2	48
<b>D53A-16A</b>			<b>140-70-11180</b>	3/4x2 3/4	6				Right HC End		18
<b>D50F-16</b>	Straight Tilt	69175	<b>140-70-11170</b>	3/4x4 1/2	4				Left HC End		18
<b>D50A-16</b>	Angle	65001-UP	<b>130-70-61170</b>	3/4x2 3/4	10	19	203	1.534	Central Cutting Edge	2	43
<b>D53A-16</b>	Angle Tilt		<b>130-70-61170HD</b>	3/4x2 3/4	10	25	203	1.534	Central Cutting Edge	2	58
<b>D53A-16A</b>			<b>140-70-11180</b>	3/4x4	4				Right HC End		18
<b>D50F-16</b>	Angle Tilt	69175-UP	<b>140-70-11170</b>	3/4x2 3/4	6				Left HC End		18
<b>D50P-16</b>	Straight Tilt	65001-UP	<b>13F-Z27-1510</b>	3/4x2 3/4	10	19	203	1.429	Central Cutting Edge	2	40
<b>D50P-17</b>	&	80001-UP	<b>13F-Z27-1510HD</b>	3/4x2 3/4	10	25	203	1.429	Central Cutting Edge	2	55
<b>D53P-16</b>	Straight	65280-UP	<b>13F-Z27-1571RF</b>	3/4x2 3/4	6	29	222	324	Straight Right End		15
<b>D53P-17</b>	Straight Tilt	80001-UP	<b>13F-Z27-1581RF</b>	3/4x4 1/2	4				Straight Left End		15
	Straight		<b>13F-Z27-1571</b>	3/4x2 3/4	6				Right HC End		17
			<b>13F-Z27-1581</b>	3/4x4 1/2	4				Left HC End		17
<b>D50A-17</b>	Straight Tilt	80001-UP	<b>130-Z20-1510</b>	3/4x2 3/4	8	19	203	1.254	Central Cutting Edge	2	35
<b>D53A-17</b>			<b>130-Z20-1510HD</b>	3/4x2 3/4	8	25	203	1.254	Central Cutting Edge	2	48
			<b>144-70-11190</b>	3/4x4	4				Right HC End		16
			<b>144-70-11180</b>	3/4x2 3/4	6				Left HC End		16

	Type	Series	Ref.	Inches		mm.			Description	n°		
					n°							
<b>D50A-17</b> <b>D53A-17</b>	Angle	80001-UP	<b>130-70-61170</b>	3/4x2 3/4	10	19	203	1.534	Central Cutting Edge	2	43	
	Angle Tilt		<b>130-70-61170HD</b>	3/4x2 3/4	10	25	203	1.534	Central Cutting Edge	2	58	
			<b>144-70-11190</b>	3/4x4	4					Right HC End		16
			<b>144-70-11180</b>	3/4x2 3/4	6					Left HC End		16
<b>D55S-2</b>	Dozer for shovel	1007-UP	<b>130-70-41130</b>	3/4x2 3/4	9	19	203	1.349	Central Cutting Edge	2	38	
			<b>130-70-41130HD</b>	3/4x2 3/4	9	25	203	1.349	Central Cutting Edge	2	51	
			<b>140-70-11180</b>	3/4x4	4					Right HC End		18
			<b>140-70-11170</b>	3/4x2 3/4	6					Left HC End		18
<b>D60A</b> <b>D60E-3</b>	Angle		<b>140-70-11120</b>	5/8x2 1/4	10	16	152	1.448	Central Cutting Edge	2	21	
			<b>140-70-11140</b>	5/8x2 1/2	5	25	197	375	Straight Right End		11	
			<b>140-70-11130</b>	5/8x2 1/2	5	25	197	375	Straight Left End		11	
<b>D60A-3</b>			<b>140-920-1120</b>	3/4x3	8	19	203	1.235	Central Cutting Edge	2	35	
			<b>140-920-1120HD</b>	3/4x3	8	25	203	1.235	Central Cutting Edge	2	47	
<b>D60A-3</b> <b>D60E-3</b> <b>D60P-3</b> <b>D-75A</b>	Straight Tilt		<b>140-70-11121</b> <b>140-920-1121</b>	3/4x2 1/2	10	19	203	1.549	Central Cutting Edge	2	44	
			<b>140-920-1121HD</b>	3/4x2 1/2	10	25	203	1.549	Central Cutting Edge	2	63	
			<b>140-70-11180</b> <b>140-70-11141</b>	3/4x3	6					Right HC End		18
			<b>140-70-11170</b> <b>140-70-11131</b>	3/4x4 1/2	4					Left HC End		18
<b>D60A-6</b> <b>D65A-6</b> <b>D60A-7</b> <b>D65A-7</b> <b>D60E-7</b> <b>65E-7</b>	Angle	20006-UP	<b>144-70-11131</b>	3/4x3	11	19	203	1.658	Central Cutting Edge	2	47	
	Angle	20000-UP	<b>144-70-11131HD</b>	3/4x3	11	25	203	1.658	Central Cutting Edge	2	63	
	Angle	40001-UP	<b>140-70-11180</b> <b>140-70-11141</b>	3/4x3	6				Right HC End		18	
			<b>140-70-11170</b> <b>140-70-11131</b>	3/4x4 1/2	4				Left HC End		18	
<b>D60A-6</b> <b>D65A-6</b> <b>D60A-7</b> <b>D65A-7</b> <b>D60E-7</b> <b>65E-7</b>	Straight Tilt	20006-UP	<b>144-920-1120</b>	3/4x2 3/4	9	19	203	1.381	Central Cutting Edge	2	39	
	Straight Tilt	20000-UP	<b>144-920-1120HD</b>	3/4x2 3/4	9	25	203	1.381	Central Cutting Edge	2	52	
	Straight Tilt	40001-UP	<b>140-70-11180</b> <b>140-70-11141</b>	3/4x2 3/4	6				Right HC End		18	
			<b>140-70-11170</b> <b>140-70-11131</b>	3/4x4 1/2	4				Left HC End		18	
<b>D60P-6</b> <b>D65P-6</b> <b>D60P-7</b> <b>D65P-7</b> <b>D60P-8</b> <b>D65P-8</b>	Straight Tilt	20006-UP	<b>144-70-11131</b>	3/4x2 3/4	11	19	203	1.658	Central Cutting Edge	2	47	
	Straight Tilt	30001-UP	<b>144-70-11131HD</b>	3/4x2 3/4	11	25	203	1.658	Central Cutting Edge	2	62	
	Straight Tilt	40001-UP	<b>13F-Z27-1571</b>	3/4x2 3/4	6				Right HC End		17	
	Straight Tilt	45001-UP	<b>13F-Z27-1581</b>	3/4x4 1/2	4				Left HC End		17	
<b>D60E-6</b>			<b>144-87-15130</b>	3/4x2 1/2	11	25	254	1.594	Central Cutting Edge	2	75	
			<b>144-87-15130HD</b>	3/4x2 1/2	11	32	254	1.594	Central Cutting Edge	2	94	
			<b>150-70-21346 /45</b> <b>150-70-21344 /43</b>	3/4x3 1/2	6					Right HC End		35
			<b>150-70-21356/55</b> <b>150-70-21354/53</b>	3/4x3 1/2	6					Left HC End		35
<b>D60P-6</b> <b>D65P-6</b> <b>D60P-7,</b> <b>D65P-7</b> <b>D60P-8,</b> <b>D65P-8</b> <b>D60P-6</b> <b>D65P-6</b> <b>D60P-7</b> <b>D65P-7</b> <b>D60P-8</b> <b>D65P-8</b>	Angle	20006-UP	<b>130-70-51130</b>	3/4	9	19	203	1.422	Central Cutting Edge	1	39	
	Angle	30001-UP	<b>130-920-2180</b>	3/4	8	19	203	1.197	Central Cutting Edge	2	33	
	Angle	40001-UP	<b>130-70-51130HD</b>	3/4	6	25	203	1.422	Central Cutting Edge	1	54	
	Angle	45001-UP	<b>130-920-2180HD</b>	3/4	8	25	203	1.197	Central Cutting Edge	2	45	
	Angle	20006-UP	<b>13F-Z27-1571RF</b>	3/4x3	6	29	222	324	Straight Right End		15	
	Angle	30001-UP	<b>13F-Z27-1581RF</b>	3/4x4 1/4	4	29	222	324	Straight Left End		15	
	Angle	40001-UP	<b>13F-Z27-1571</b>	3/4x 3	6				Right HC End		17	
	Angle	45001-UP	<b>13F-Z27-1581</b>	3/4x4 1/2	4				Left HC End		17	
<b>D60A-6</b> <b>D65A-6</b> <b>D60E-6</b> <b>D65E-6</b>	Angle Tilt	20006-UP	<b>154-70-11313/14</b>	3/4x3 1/4	8	25	254	1.156	Central Cutting Edge	2	55	
	Angle Tilt	20000-UP	<b>154-70-11313/14 HD</b>	3/4x3 1/4	8	32	254	1.156	Central Cutting Edge	3	69	
	Angle Tilt	20295-UP	<b>150-70-21345/46</b>	3/4x3 1/4	6				Right HC End		35	





	Type	Series	Ref.	Inches		mm.				Description	n°	
					n°							
<b>D60A-7</b> <b>D60E-7</b> <b>D65A-7P,</b> <b>65E-7</b>	Angle Tilt	40001-UP	<b>150-70-21343/44</b> <b>150-70-21355/56</b> <b>150-70-21353/54</b>	3/4x3 1/4	6					Left HC End		35
<b>D60A-8</b> <b>D60E-8</b> <b>D65A-8</b> <b>D65E-8</b>	Angle	45001-UP	<b>144-70-11131</b> <b>144-70-1131HD</b> <b>144-70-11260</b> <b>144-70-11250</b>	3/4x2 1/2 3/4x2 1/2 3/4x3 3/4x4 1/2	11 11 6 4	19 25	203 203	1.658 1.658		Central Cutting Edge Central Cutting Edge Right HC End Left HC End	2 2	47 63 16 16
<b>D60PL-7</b> <b>D60PL-8</b>	Straight Tilt	40001-UP 45001-UP	<b>12F-70-31251</b> <b>13F-A70-1580</b> <b>13F-A70-1570</b>	5/8x2 1/4 5/8x2 1/4 5/8x3 1/2	5 6 4	16	152	760		Central Cutting Edge Right HC End Left HC End	5	13 10 10
<b>D60A-8</b> <b>D60E-8</b> <b>D65A-8</b> <b>D65E-8</b>	Reinforced Angle	45001-UP	<b>144-70-11131</b> <b>144-70-1131HD</b> <b>140-70-11180/141</b> <b>140-70-11170/131</b>	3/4x3 3/4x3 3/4x3 3/4x4 1/2	11 11 6 4	19 25	203 203	1.658 1.658		Central Cutting Edge Central Cutting Edge Right HC End Left HC End	2 2	47 63 18 18
	Straight Tilt	45001-UP	<b>144-920-1120</b> <b>144-920-1120HD</b> <b>140-70-11180/141</b> <b>140-70-11170/131</b>	3/4x2 3/4 3/4x2 3/4 3/4x2 3/4 3/4x4 1/2	9 9 6 4	19 25	203 203	1.381 1.381		Central Cutting Edge Central Cutting Edge Right HC End Left HC End	2 2	39 52 18 18
	Angle Tilt	45001-UP	<b>154-70-11313/14</b> <b>154-70-11313/14 HD</b> <b>150-70-21345/46</b> <b>150-70-21343/44</b> <b>150-70-21355/56</b> <b>150-70-21353/54</b>	3/4x3 1/4 3/4x3 1/4 3/4x3 1/4 3/4x3 1/4	8 8 6 6	25 32	254 254	1.156 1.156		Central Cutting Edge Central Cutting Edge Right HC End Left HC End	3 3	55 69 35 35
<b>D80A</b> <b>D85A</b> <b>D85A-12</b> <b>D80A-18</b> <b>D80E-18</b> <b>D85A-18</b>	Straight Straight Tilt Straight Tilt	10001-UP 25001-UP	<b>154-70-11313/14</b> <b>154-81-11190/91</b> <b>154-70-11313/14 HD</b> <b>154-81-11190/91 HD</b> <b>150-70-21345/46</b>	3/4x2 1/2 3/4x2 1/2 3/4x2 1/2 3/4x2 1/2 3/4x3 1/2	8 6 8 6 6	25 25 32 32	254 254 254 254	1.156 837 1.156 837		Central Cutting Edge Central Cutting Edge Central Cutting Edge Central Cutting Edge Straight Right End	1 2 1 2	55 40 69 50 35
<b>D85E-18</b>			<b>150-70-21343/44</b> <b>150-70-21355/56</b> <b>150-70-21353/54</b>	3/4x3 1/2	6					Straight Left End		35
<b>D80A</b> <b>D80A-8</b>	Angle		<b>150-70-21311</b> <b>150-70-21311 HD</b> <b>150-70-21312/14</b> <b>150-70-21312/14 HD</b> <b>150-70-21342</b> <b>150-70-21352</b>	3/4x2 1/2 3/4x2 1/2 3/4x2 1/2 3/4x2 1/2 3/4x3 3/4x3	10 10 11 11 6 6	25 32	254 254	1.473 1.473 1.664 1.664		Central Cutting Edge Central Cutting Edge Central Cutting Edge Central Cutting Edge Straight Right End Straight Left End	2 2 2 2	72 88 77 100 39 39
<b>D80A</b> <b>D85A</b>			<b>154-81-11190/91</b> <b>154-81-11190/91 HD</b>	3/4x2 1/2 3/4x2 1/2	6 6	25 25	254 254	837 837		Central Cutting Edge Central Cutting Edge	3 3	40 50
<b>D80A-18</b> <b>D80E-18</b> <b>D85A-18</b> <b>D85E-18</b>	Angle	25001-UP	<b>154-70-11313/14</b> <b>154-70-11313/14 HD</b> <b>150-70-21345/46</b> <b>150-70-21343/44</b>	3/4x2 1/2 3/4x2 1/2 3/4x3 1/2	8 8 6	25 32	254 254	1.156 1.156		Central Cutting Edge Central Cutting Edge Straight Right End	3 3	55 69 35
<b>D80P-18</b> <b>D85P-18</b>	Straight Tilt	2001-UP	<b>150-70-21355/56</b> <b>150-70-21353/54</b>	3/4x3 1/2	6					Straight Left End		35
<b>D80A-12</b> <b>D80E-12</b> <b>D85A-12</b> <b>D85E-12</b>	"U"	15478-UP	<b>154-72-11121</b> <b>154-72-11121HD</b> <b>154-72-11150</b> <b>154-72-11150HD</b> <b>150-70-21345/46</b>	3/4x2 1/2 3/4x2 1/2 3/4x2 1/2 3/4x2 1/2 3/4x3 1/2	9 9 6 6 6	25 32	254 254	1.384 1.384 908 908		Central Cutting Edge Central Cutting Edge Side Cutting Edge Side Cutting Edge Right HC End		65 81 44 54 35





	Type	Series	Ref.	Inches	n°	mm.			Description	n°	
			<b>150-70-21343/44</b> <b>150-70-21355/56</b> <b>150-70-21353/54</b>	3/4x3 1/2	6				Left HC End		35
<b>D120A-18</b> <b>D125A-18</b>	Angle		<b>175-70-11120/21</b> <b>175-70-11120/21 HD</b> <b>170-70-11195</b> <b>170-70-11185</b>	3/4x3 3/4x3 3/4x3 1/2 3/4x3 1/2	13 13 7 7	25 32	254 254	1.927 1.927	Central Cutting Edge Central Cutting Edge Right HC End Left HC End	2 2	93 116 33 33
<b>D125A</b> <b>D125A-18</b>	Straight Tilt		<b>175-901-1130</b> <b>175-901-1130HD</b> <b>170-901-1233</b> <b>170-901-1223</b>	3/4x4 1/2 3/4x4 1/2 3/4x4 1/2 3/4x4 1/2	10 10 7 7	25 32	254 254	1.508 1.508	Central Cutting Edge Central Cutting Edge Right HC End Left HC End	2 2	73 90 44 44
<b>D150A-1</b> <b>D155A-1</b>	Straight Tilt Straight Tilt	5508-8328 5508 a 10262	<b>175-71-111240/41/42</b> <b>175-71-111240/41/42 HD</b> <b>175-71-11180/82-22281</b> <b>175-71-11170/72-22271</b>	7/8x4 7/8x4 7/8x4 7/8x4	10 10 7 7	25 32	254 254	1.508 1.508	Central Cutting Edge Central Cutting Edge Right HC End Left HC End	2 2	73 91 49 49
<b>D150A-1</b> <b>D155A-1</b>	Straight Tilt Straight Tilt	8329-UP 10263-UP	<b>175-70-26310</b> <b>175-70-26310HD</b> <b>175-71-22282</b> <b>175-71-22272</b>	7/8x3 1/2 7/8x3 1/2 7/8x3 1/2 7/8x5	7 7 8 6	25 32	254 254	1.062 1.062	Central Cutting Edge Central Cutting Edge Right HC End Left HC End	3 3	51 64 41 41
<b>D150A-1</b> <b>D155A-1</b>	Angle Angle	5513-8328 5513-10262	<b>175-70-21112/13/14</b> <b>175-70-21112/13/14 HD</b> <b>175-70-21133/35</b> <b>175-70-21123/25</b>	  7/8x3 1/2 7/8x3 1/2	  7 7				  Right HC End Left HC End		  35 35
<b>D150A-1</b> <b>D155A-1</b>	Angle Angle	8329-UP 10263-UP	<b>175-70-26310</b> <b>175-70-21115</b> <b>175-70-26310HD</b> <b>175-70-21115HD</b> <b>175-70-21136</b> <b>175-70-21126</b>	7/8x3 7/8x3 7/8x3 7/8x3 7/8x3 1/2 7/8x3 1/2	7 9 7 9 7 7	25 25 32 32	254 254 254 254	1.062 1.397 1.062 1.397	Central Cutting Edge Central Cutting Edge Central Cutting Edge Central Cutting Edge Right HC End Left HC End	1 2 1 2	51 68 64 85 43 43
<b>D150A-1</b> <b>D155A-1</b>	"U"	6843-8328 6843-10262	<b>175/72/21120/21/22</b> <b>175-70-21112/13/14 HD</b> <b>175-72-21131/32/33</b> <b>175-72-21131/32/33 HD</b> <b>175-72-22250/51-21151</b> <b>175-72-22240/41-21141</b>	7/8x3 7/8x3 7/8x3 7/8x3 7/8x3 1/2 7/8x3 1/2	13 13 7 7 7 7	25 32	254 254 254 254	1.670 1.670 876 876	Central Cutting Edge Central Cutting Edge Side Cutting Edge Side Cutting Edge	2 2	79 99 42 53
<b>D150A-1</b> <b>D155A-1</b>	"U"	8329-UP 10263-UP	<b>175-72-21123</b> <b>175-72-21123HD</b> <b>175-72-21123</b> <b>175-72-21123HD</b> <b>175-70-21136</b> <b>175-70-21126</b>	7/8x3 7/8x3 7/8x3 7/8x3 7/8x3 1/2 7/8x3 1/2	6 6 6 6 7 7	25 32	254 254 254 254	902 902 902 902	Central Cutting Edge Central Cutting Edge Side Cutting Edge Side Cutting Edge Right HC End Left HC End	2 2	43 54 43 54 43 43
<b>D150A-1</b> <b>D155A-1</b>	Angle Tilt	6843-8407 6843-15000	<b>175-70-26310</b> <b>175-70-26310HD</b> <b>175-70-21333/35</b> <b>175/70/21123/25</b>	7/8x3 1/2 7/8x3 1/2 7/8x3 1/2 7/8x3 1/2	7 7 7 7	25 32	254 254	1.062 1.062	Central Cutting Edge Central Cutting Edge Right HC End Left HC End	4 4	51 64 35 35
<b>D150A-1</b> <b>D155A-1</b>	Angle Tilt	8408-UP 15001-UP	<b>175-70-21115</b> <b>175-70-21115HD</b> <b>175-70-21136</b> <b>175-70-21126</b>	7/8x3 7/8x3 7/8x3 1/2 7/8x3 1/2	9 9 7 7	25 32	254 254	1.397 1.397	Central Cutting Edge Central Cutting Edge Right HC End Left HC End	3 3	68 85 43 43
<b>D355A-1</b>	Straight Tilt Straight	1010-1121 1122-1631	<b>195-71-11651/53</b> <b>195-71-11651/53 HD</b>	1x3 1/2 1x3 1/2	10 10	32 38	305 305	1.535 1.535	Central Cutting Edge Central Cutting Edge	2 2	107 128

	Type	Series	Ref.	Inches		mm.			Description	n°	
					n°						
			<b>195-71-11180/81/82</b>	1x3 1/2	7				Right HC End		74
			<b>195-71-11170/71/72</b>	1x3 1/2	7				Left HC End		74
<b>D355A-1</b>	Straight Tilt	1632-UP	<b>195-71-11654</b>	1"	7	32	330	1.064	Central Cutting Edge	3	83
			<b>195-71-11654HD</b>	1"	7	38	330	1.064	Central Cutting Edge	3	100
			<b>195-71-11183</b>	1"	7				Right HC End		68
			<b>195-71-11173</b>	1"	7				Left HC End		68
	Angle	1632-UP	<b>195-70-12492</b>	1"	9	32	330	1.327	Central Cutting Edge	3	102
			<b>195-70-12492HD</b>	1"	9	38	330	1.327	Central Cutting Edge	3	122
<b>195-70-12620</b>			1"	7				Right HC End		65	
<b>195-70-12610</b>			1"	7				Left HC End		65	
<b>D355A-1</b>	"U"	1010-1631	<b>195-72-11140/43</b>	1"	13	32	305	1.975	Central Cutting Edge		137
			<b>195-72-11140/43 HD</b>	1"	13	38	305	1.975	Central Cutting Edge		164
			<b>195-72-1120/21</b>	1"	7				Right HC End		55
			<b>195-72-11130/31</b>	1"	7				Left HC End		55
<b>D355A-3</b>	"U"	1632-UP	<b>195-72-11144</b>	1"	6	32	330	879	Central Cutting Edge	2	67
			<b>195-72-11144HD</b>	1"	6	38	330	879	Central Cutting Edge	2	81
			<b>195-70-12620</b>	1"	7				Right HC End		65
			<b>195-70-12610</b>	1"	7				Left HC End		65
<b>D375A-1</b>	Straight Tilt	15001-15207	<b>195-71-11654</b>	1"	7	32	330	1.064	Central Cutting Edge	2	83
			<b>195-71-51120</b>	1"	5	32	330	710	Central Cutting Edge	2	53
			<b>195-71-11654HD</b>	1"	7	38	330	1.064	Central Cutting Edge	2	100
			<b>195-71-51120HD</b>	1"	5	38	330	710	Central Cutting Edge	2	64
			<b>195-70-12620</b>	1"	7				Right HC End		65
			<b>195-70-12610</b>	1"	7				Left HC End		65
	"U" Tilt	15001-15217	<b>195-70-12492</b>	1"	9	32	330	1.327	Central Cutting Edge	3	102
			<b>195-70-12492HD</b>	1"	9	38	330	1.327	Central Cutting Edge	3	122
			<b>195-71-51120</b>	1"	5	32	330	710	Side Cutting Edge		53
			<b>195-71-51120HD</b>	1"	5	38	330	710	Side Cutting Edge		64
			<b>195-70-12620</b>	1"	7				Right HC End		65
			<b>195-70-12610</b>	1"	7				Left HC End		65
	Straight, Tilt Reinf. St. Tilt	15218-UP	<b>195-71-51651</b>	1 1/8x3 3/4	7	32	330	1.064	Central Cutting Edge	2	80
			<b>195-71-51661</b>	1 1/8x3 3/4	5	32	330	710	Central Cutting Edge	2	52
			<b>195-71-51651HD</b>	1 1/8x3 3/4	7	38	330	1.064	Central Cutting Edge	2	97
			<b>195-71-51661HD</b>	1 1/8x3 3/4	5	38	330	710	Central Cutting Edge	2	63
			<b>195-71-51641</b>	1 1/8x4 1/8	7				Right HC End		73
			<b>195-71-51631</b>	1 1/8x4 1/8	7				Left HC End		73
	"U"	15218-UP	<b>195-71-51671</b>	1 1/8x3 3/4	9	32	330	1.327	Central Cutting Edge	2	100
			<b>195-71-51671HD</b>	1 1/8x3 3/4	9	38	330	1.327	Central Cutting Edge	2	121
			<b>195-71-51661</b>	1 1/8x3 3/4	5	32	330	710	Side Cutting Edge		52
			<b>195-71-51661HD</b>	1 1/8x3 3/4	5	38	330	710	Side Cutting Edge		63
			<b>195-71-51641</b>	1 1/8x4 1/8	7				Right HC End		73
			<b>195-71-51631</b>	1 1/8x4 1/8	7				Left HC End		73
<b>D455A-1</b>	Semi U Tilt	1002-UP	<b>198-71-11181</b>	1 1/4x4	8	38	406	1.191	Central Cutting Edge	2	130
			<b>198-71-11181HD</b>	1 1/4x4	8	44	406	1.191	Central Cutting Edge	2	153
			<b>198-72-11181</b>	1 1/4x4	5	38	406	860	Side Cutting Edge		92
			<b>198-72-11181HD</b>	1 1/4x4	5	44	406	860	Side Cutting Edge		108
			<b>198-72-11160</b>	1 1/4x4	8				Right HC End		114
			<b>198-72-11170</b>	1 1/4x5 1/2	8				Left HC End		114
	"U" Tilt	1002-UP	<b>198-71-11181</b>	1 1/4x4	8	38	406	1.191	Central Cutting Edge	1	130
			<b>198-72-11181</b>	1 1/4x4	5	38	406	860	Central Cutting Edge	2	92
			<b>198-71-11181HD</b>	1 1/4x4	8	44	406	1.191	Central Cutting Edge	1	153

	Type	Series	Ref.	Inches		mm.			Description	n°		
					n°							
			<b>198-72-11181HD</b>	1 1/4x4	5	44	406	860	Central Cutting Edge	2	108	
			<b>198-71-11181</b>	1 1/4x4	8	38	406	1.191	Side Cutting Edge		130	
			<b>198-71-11181HD</b>	1 1/4x4	8	44	406	1.191	Side Cutting Edge		153	
			<b>198-72-11160</b>	1 1/4x4	8					Right HC End		114
			<b>198-72-11170</b>	1 1/4x5 1/2	8					Left HC End		114
<b>D475A-1</b>	Straight Tilt	10001-UP	<b>198-71-21830</b>	1 3/8x4 1/2	8	38	406	1.191	Central Cutting Edge	2	127	
			<b>198-71-21840</b>	1 3/8x4 1/2	5	38	406	860	Central Cutting Edge	2	90	
			<b>198-71-21830HD</b>	1 3/8x4 1/2	8	44	406	1.191	Central Cutting Edge	2	151	
			<b>198-71-21840HD</b>	1 3/8x4 1/2	5	44	406	860	Central Cutting Edge	2	106	
			<b>198/71-21820/21</b>	1 3/8x5 3/8	4					Right HC End		112
			<b>198-71-21810/11</b>	1 3/8x5 3/8	4					Left HC End		112
	"U" Tilt	10001-UP	<b>198-71-21830</b>	1 3/8x4 1/2	8	38	406	1.191	Central Cutting Edge	1	127	
			<b>198-71-21840</b>	1 3/8x4 1/2	5	38	406	860	Central Cutting Edge	2	90	
			<b>198-71-21830HD</b>	1 3/8x4 1/2	8	44	406	1.191	Central Cutting Edge	1	151	
			<b>198-71-21840HD</b>	1 3/8x4 1/2	5	44	406	860	Central Cutting Edge	2	106	
<b>D475A-1</b>	"U" Tilt	10001-UP	<b>198-71-21830</b>	1 3/8x4 1/2	8	38	406	1.191	Side Cutting Edge		127	
			<b>198-71-21830HD</b>	1 3/8x4 1/2	8	44	406	1.191	Side Cutting Edge		151	
			<b>198/71-21820/21</b>	1 3/8x5 3/8						Right HC End		112
			<b>198-71-21810/11</b>	1 3/8x5 3/8						Left HC End		112

## Loader Bolt-On Cutting Edges

	Series		Type	n°		n°		n°		n°
<b>WA70-1</b>	10001 -	<b>415-815-1110</b>	Central	1	02090-11060	11	02290-11016	11	01643-31645	11
		<b>415-815-1120</b>	Lateral	2						
<b>WA100-1</b>	10001-19999	<b>416-815-1110</b>	Central	1	02090-11275	8	02290-11219	8	01643-32060	8
		<b>416-815-1120</b>	Lateral	2						
	20001-	<b>416-815-1210*</b>	Central	1						
		<b>416-815-1220*</b>	Lateral	2						
		<b>416-816-1310**</b>	Central	1						
<b>416-816-1320**</b>	Lateral	2								
<b>WA-120-1</b>	10001-	<b>416-816-1310</b>	Central	1	02090-11275	8	02290-11219	8	01643-32060	8
		<b>416-816-1320</b>	Lateral	2						
<b>WA-120-3</b>	50001-	<b>416-815-1310</b>	Central	1	02090-11275	8	02290-11219	8	01643-32060	8
		<b>416-815-1320</b>	Lateral	2						
<b>WA150-1</b>	10001-19999	<b>416-815-1110</b>	Central	1	02090-11275	8	02290-11219	8	01643-32060	8
		<b>416-815-1120</b>	Lateral	2						
	20001-	<b>416-815-1310</b>	Central	1						
		<b>416-815-1320</b>	Lateral	2						
<b>WA180-1</b>	10001-	<b>417-815-1210</b>	Central	1	02090-11475	8	02290-11422	8	01643-32260	8
		<b>417-815-1220</b>	Lateral	2						
<b>WA180-3</b>	50001-	<b>417-815-1210</b>	Central	1	02090-11475	8	02290-11422	8	01643-32260	8
		<b>417-815-1220</b>	Lateral	2						
<b>WA200-1</b>	100001-19999	<b>417-815-1120</b>	Central	1	02090-11475	8	02290-11422	8	01643-32260	8
		<b>418-815-1110</b>	Lateral	2						
	20001-	<b>417-815-1210</b>	Central	1						
		<b>417-815-1220</b>	Lateral	2						
<b>WA250-1</b>	10001-	<b>418-815-1211</b>	Central	1	02090-11685	8	02290-11625	8	01643-22460	8
		<b>418-815-1221</b>	Lateral	2						
<b>WA250-3</b>	50001-	<b>418-815-1211</b>	Central	1	02090-11685	8	02290-11625	8	01643-22460	8
		<b>418-815-1221</b>	Lateral	2						
<b>WA300-1</b>	10001-19999	<b>419-815-1110</b>	Central	1	02090-11685	8	02090-11685	8	01643-22460	8
		<b>419-815-1120</b>	Lateral	2						
	20001-	<b>418-815-1211</b>	Central	1						
		<b>418-815-1221</b>	Lateral	2						
<b>WA320-1</b>	10001-	<b>419-815-1211</b>	Central	1	02090-11685	8	02090-11625	8	01643-22460	8
		<b>418-815-1221</b>	Lateral	2						
<b>WA320-3</b>	50001-	<b>418-815-1211</b>	Central	1	02090-11685	8	02090-11625	8	01643-22460	8
		<b>418-815-1221</b>	Lateral	2						
<b>WA-350-1</b>	10001-	<b>423-815-1110</b>	Central	1	02090-11490	14	02290-11422	14	01643-32260	14
		<b>423-815-1120</b>	Lateral	2						
<b>WA380-1</b>	10001-19999	<b>423-815-1210</b>	Central	1	02090-11490	14	02290-11422	14	01643-32260	14
		<b>423-815-1220</b>	Lateral	2						
	20001	<b>423-815-1211</b>	Central	1						
		<b>423-815-1221</b>	Lateral	2						
<b>WA380-3</b>	50001-	<b>424-815-1111</b>	Central	1	02090-11485	14	02290-11422	14	01643-32260	14
		<b>424-815-1131</b>	Lateral	2						
<b>WA400-1</b>	10001-	<b>424-815-1111</b>	Central	1	02090-11485	14	02290-11422	14	01643-32260	14
		<b>424-815-1131</b>	Lateral	2						
<b>WA420-1</b>	10001-	<b>424-815-1211</b>	Central	1	02090-11485	14	02290-11422	14	01643-32260	14
		<b>421-815-1221</b>	Lateral	2						

	Series		Type	n°		n°		n°		n°
<b>WA420-3</b>	50001-	<b>424-815-1211</b>	Central	1	02090-11485	16	02290-11422	16	01643-32260	16
		<b>421-815-1221</b>	Lateral	2						
<b>WA450-1</b>	10001-	<b>421-815-1111</b>	Central	1	02090-11485	16	02290-11422	16	01643-32260	16
		<b>421-815-1131</b>	Lateral	2						
<b>WA470-1</b>	10001-	<b>421-815-1211</b>	Central	1	02090-11485	16	02290-11422	16	01643-32260	16
		<b>421-815-1221</b>	Lateral	2						
<b>WA470-3</b>	50001-	<b>421-815-1211</b>	Central	1	02090-11485	16	02290-11422	16	01643-32260	16
		<b>421-815-1221</b>	Lateral	2						
<b>WA500-1</b>	10001-19999	<b>425-815-1110</b>	Central	1	02091-11605	16	02290-11625	16	01643-32780	16
		<b>425-815-1120</b>	Lateral	2						
	20001-	<b>425-815-1310</b>	Central	1						
		<b>425-815-1320</b>	Lateral	2						
	10001-	<b>4215-815-1510</b>	Central	1						
		<b>425-815-1520</b>	Lateral	2						
<b>WA-600-1</b>	10001-	<b>426-815-1110</b>	Central	1	02091-12030	16	02290-12031	16	01643-33380	16
		<b>426-815-1120</b>	L.H.	2						
		<b>426-815-1130</b>	R.H.	2						



## Loader Multi-Purpose Bucket Edge

	Serie	Ref.	n°		n°		n°		n°
<b>WA70-1</b>	10001-	<b>415-823-1311</b>	1	02090-10840	13	02290-10813	13	01643-31445	13
		<b>415-823-1321</b>	2						
<b>WA100-1</b>	10001-	<b>417-823-1310</b>	1	02090-11045	16	02290-11016	16	01643-31645	16
		<b>418-823-1320</b>	2						
<b>WA-120-3</b>	50001-	<b>417-823-1310</b>	1	02090-11045	16	02290-11016	16	01643-31645	16
		<b>418-823-1320</b>	2						
<b>WA-150-1</b>	10001-	<b>417-823-1310</b>	1	02090-11045	16	02290-11016	16	01643-31645	16
		<b>417-823-1320</b>	2						
<b>WA180-1</b>	10001-	<b>418-823-1310</b>	1	02090-11045	16	02290-11016	16	01643-31645	16
		<b>418-823-1320</b>	2						
<b>WA180-3</b>	50001-	<b>418-823-1310</b>	1	02090-11045	16	02290-11016	16	01643-31645	16
		<b>418-823-1320</b>	2						
<b>WA200-1</b>	10001-	<b>418-823-1310</b>	1	02090-11045	16	02290-11016	16	01643-31645	16
		<b>418-823-1320</b>	2						
<b>WA300-1</b>	10001-	<b>419-823-1310</b>	1	02090-11260	18	02290-11219	18	01643-32060	18
		<b>423-823-1320</b>	2						
<b>WA350-1</b>	10001-	<b>423-823-1310</b>	1	02090-11260	18	02290-11219	18	01643-32060	18
		<b>423-823-1320</b>	2						

## Loader Segments

	Serie	Ref.	n°		n°		n°		n°
<b>WA250-1</b>	10001-	<b>419-838-1110</b>	5	02090-11690	14	02290-11625	14	01643-22460	14
		<b>421-838-1110</b>	2						
<b>WA300-1</b>	10001-	<b>419-838-1120</b>	5	02090-11690	14	02290-11625	14	01643-22460	14
		<b>421-838-1110</b>	2						
<b>WA320-1</b>	10001-	<b>419-838-1110</b>	5	02090-11690	14	02290-11625	14	01643-22460	14
		<b>418-823-1320</b>	2						
<b>WA380-1</b>	10001-	<b>421-838-1110</b>	7	02091-11600	14	02290-11625	14	01643-22460	14
<b>WA420-1</b>	10001-	<b>421-838-1120</b>	2	02091-11600	16	02290-11625	16	01643-22460	16
		<b>421-838-1110</b>	6						
<b>WA450-1</b>	10001-	<b>421-838-1120</b>	2	02091-11600	16	02290-11625	16	01643-22460	16
		<b>418-823-1320</b>	6						
<b>WA470-1</b>	10001-	<b>421-838-1120</b>	2	02091-11600	16	02290-11625	16	01643-22460	16
		<b>421-838-1110</b>	6						
<b>WA470-3</b>	50001-	<b>421-838-1120</b>	2	02091-11600	16	02290-11625	16	01643-22460	16
		<b>423-823-1320</b>	2						
<b>WA500-1</b>	10001-	<b>421-838-1110</b>	1	02091-12015	14	02290-12031	14	01643-33380	14



## Hardness-strength Conversion

Hardness Rockwell		Hardness Vickers	Hardness Brinell	PSI	Resistance Kg/mm2
HRB	HRC	HV	HB		
-	-	245	229	113,500	80
-	22	250	235	116,000	82
-	23	256	241	119,000	84
-	24	263	244	120,500	85
-	25	270	248	122,000	86
-	26	275	255	126,000	89
-	27	281	262	129,000	91
-	28	283	269	133,000	94
-	29	295	277	138,000	97
-	30	302	285	142,000	100
-	31	310	294	146,000	103
-	32	316	299	147,500	104
-	33	325	302	150,000	106
-	34	334	311	154,500	109
-	35	341	321	159,000	112
-	36	350	331	163,000	115
-	37	360	341	168,500	119
-	38	370	352	174,500	123
-	39	380	363	180,000	127
-	40	390	376	185,500	131
-	41	401	388	192,500	136
-	42	414	394	195,500	138
-	43	426	401	198,500	140
100	44	439	415	205,000	145
-	45	450	429	212,000	150
-	46	465	436	215,000	152
-	47	472	444	220,000	155
-	48	492	461	228,000	161
-	49	508	477	237,000	167
-	50	525	486	251,000	170
-	51	540	496	253,000	175
-	52	560	512	262,000	180
-	53	575	525	269,000	183
-	54	595	543	278,000	187
-	55	610	560	287,000	-
-	56	630	577	295,000	-
-	57	650	595	305,000	-
-	58	670	615	315,000	-
-	59	690	634	325,000	-
-	60	720	654	-	-
-	61	740	670	-	-
-	62	760	688	-	-
-	63	785	705	-	-
-	64	-	722	-	-
-	65	-	739	-	-

## Dimension Conversion

Inch	mm.	Decimals "	cm.	Inch
1/64	0,397	0,0156	0,05	0,0197
1/32	0,794	0,0313	0,10	0,0394
1/16	1,588	0,0625	0,15	0,0591
3/32	2,382	0,0938	0,20	0,0787
1/8	3,175	0,1250	0,25	0,0984
5/32	3,970	0,1563	0,30	0,1181
3/16	4,763	0,1875	0,35	0,1378
7/32	5,556	0,2188	0,40	0,1575
1/4	6,350	0,2500	0,45	0,1772
9/32	7,144	0,2813	0,50	0,1969
5/16	7,938	0,3125	0,55	0,2165
11/32	8,732	0,3438	0,60	0,2362
3/8	9,525	0,3750	0,65	0,2559
13/32	10,319	0,4063	0,70	0,2756
7/16	11,113	0,4375	0,75	0,2953
15/32	11,906	0,4688	0,80	0,3150
1/2	12,700	0,5000	0,85	0,3346
17/32	13,494	0,5313	0,90	0,3543
9/16	14,288	0,5625	0,95	0,3740
19/32	15,081	0,5938	1	0,3937
5/8	15,875	0,6250	2	0,7874
21/32	16,669	0,6563	3	1,1811
11/16	17,463	0,6875	4	1,5748
23/32	18,256	0,7187	5	1,9685
3/4	19,050	0,7500	6	2,3622
25/32	19,844	0,7813	7	2,7559
13/16	20,638	0,8125	8	3,1496
27/32	21,481	0,8457	9	3,5433
7/8	22,225	0,8750	10	3,9370
29/32	23,019	0,9063	20	7,8740
15/16	23,813	0,9375	30	11,8110
31/32	24,606	0,9687	40	15,7480
1	25,400	1,0000	50	19,6850

### Dimensions

1 Inch = 25,4 mm.	1 Yard = 91,44 cm.
1 Inch = 2,54 cm.	1 Yard = 0,9144 m.
1 Foot = 30,48 cm.	1 Mile = 1609,3 m.
1 Foot = 0,3048 m.	1 Mile = 1,6093 Km.

### Weight

1 Ounce = 28,3 gr.	10 Pounds = 4,5359 Kg.
1 Pound = 453,5 gr.	1 Ton U.S.A. = 907,18 Kg.

Pounds	Grams	Kilograms
0,2	90,7185	0,0907
0,4	181,4370	0,1814
0,6	272,1555	0,2722
0,8	362,8740	0,3629
1	453,5925	0,4536
2	907,1850	0,9072
3	1360,7775	1,3608
4	1814,3700	1,8144
5	2267,9625	2,2680